

NATIONAL ELIGIBILITY CUM ENTRANCE TEST (UG) SET :
[NEET-2022], Test held on 17th July 2022 T-6

Subject : PHYSICS

1. If a soap bubble expands, the pressure inside the bubble :
- (1) increases
 - (2) remains the same
 - (3) is equal to the atmospheric pressure
 - (4) decreases
2. The graph which shows the variation of the de-Broglie wavelength (λ) of a particle and its associated momentum (p) is :

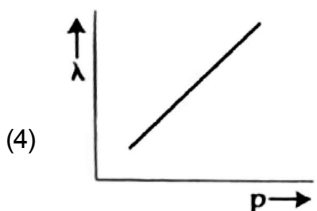
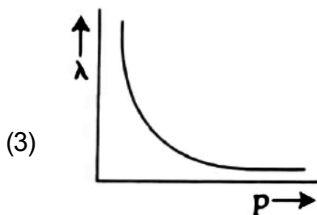
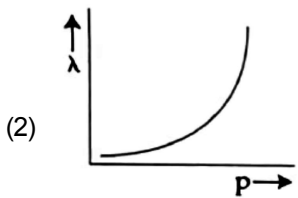
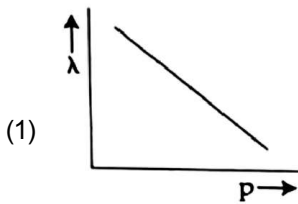

3. A body of mass 60g experiences a gravitational force of 3.0 N, when placed at a particular point. The magnitude of the gravitational field intensity at that point is :

- (1) 50 N/kg
- (2) 20 N/kg
- (3) 180 N/kg
- (4) 0.05 N/kg

4. Given below are two statements :

Statement I :

Biot-Savart's law gives us the expression for the magnetic field strength of an infinitesimal current element (Idl) of a current carrying conductor only.

Statement II :

Biot-Savart's law is analogous to Coulomb's inverse square law of charge q , with the former being related to the field produced by a scalar source, Idl while the latter being produced by a vector source, q .

In light of above statements choose the most appropriate answer from the options given below:

- (1) Both Statement I and Statement II are incorrect
 - (2) Statement I is correct and Statement II is incorrect
 - (3) Statement I is incorrect and Statement II is correct
 - (4) Both Statement I and Statement II are correct
5. The ratio of the distances travelled by a freely falling body in the 1st, 2nd, 3rd and 4th second
- (1) 1 : 4 : 9 : 16
 - (2) 1 : 3 : 5 : 7
 - (3) 1 : 1 : 1 : 1
 - (4) 1 : 2 : 3 : 4
6. In half wave rectification, if the input frequency is 60 Hz, then the output frequency would be :
- (1) 30 Hz
 - (2) 60 Hz
 - (3) 120 Hz
 - (4) zero

7. A spherical ball is dropped in a long column of a highly viscous liquid. The curve in the graph shown, which represents the speed of the ball (v) as a function of time (t) is :

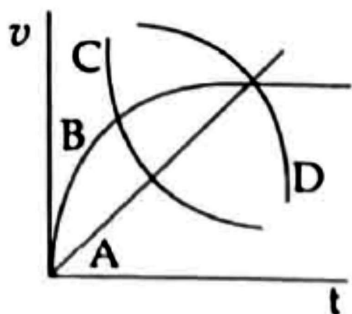

- (1) B
(2) C
(3) D
(4) A
8. The angle between the electric lines of force and the equipotential surface is :
- (1) 45°
(2) 90°
(3) 180°
(4) 0°
9. As the temperature increases, the electrical resistance :
- (1) decreases for both conductors and semiconductors
(2) increases for conductors but decreases for semiconductors
(3) decreases for conductors but increases for semiconductors
(4) increases for both conductors and semiconductors
10. In the given nuclear reaction, the element X is :

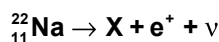

- (1) ${}_{10}^{23}\text{Ne}$
(2) ${}_{10}^{22}\text{Ne}$
(3) ${}_{12}^{22}\text{Mg}$
(4) ${}_{11}^{23}\text{Mg}$
11. Let T_1 and T_2 be the energy of an electron in the first and second excited states of hydrogen atom, respectively. According to the Bohr's model of an atom, the ratio $T_1 : T_2$ is :
- (1) 4 : 1
(2) 4 : 9
(3) 9 : 4
(4) 1 : 4

12. The ratio of the radius of gyration of a thin uniform disc about an axis passing through its centre and normal to its plane to the radius of gyration of the disc about its diameter is :

- (1) $\sqrt{2} : 1$
(2) 4 : 1
(3) $1 : \sqrt{2}$
(4) 2 : 1

13. When light propagates through a material medium of relative permittivity ϵ_r , and relative permeability μ_r , the velocity of light, v is given by : (c-velocity of light in vacuum)

- (1) $v = \sqrt{\frac{\mu_r}{\epsilon_r}}$
(2) $v = \sqrt{\frac{\epsilon_r}{\mu_r}}$
(3) $v = \frac{c}{\sqrt{\epsilon_r \mu_r}}$
(4) $v = c$

14. The energy that will be ideally radiated by a 100 kW transmitter in 1 hour is :

- (1) $36 \times 10^4 \text{ J}$
(2) $36 \times 10^5 \text{ J}$
(3) $1 \times 10^5 \text{ J}$
(4) $36 \times 10^7 \text{ J}$

15. An electric lift with a maximum load of 2000 kg (lift +passengers) is moving up with a constant speed of 1.5 ms^{-1} . The frictional force opposing the motion is 3000 N. The minimum power delivered by the motor to the lift in watts is : ($g = 10 \text{ ms}^{-2}$) :

- (1) 20000
(2) 34500
(3) 23500
(4) 23000

16. Two resistors of resistance, 100Ω and 200Ω are connected in parallel in an electrical circuit. The ratio of the thermal energy developed in 100Ω to that in 200Ω in a given time is :

- (1) 2 : 1
(2) 1 : 4
(3) 4 : 1
(4) 1 : 2

17. The peak voltage of the ac source is equal to :

- (1) the rms value of the ac source
- (2) $\sqrt{2}$ times the rms value of the ac source
- (3) $1/\sqrt{2}$ times the rms value of the ac source
- (4) the value of voltage supplied to the circuit.

18. A shell of mass m is at rest initially. It explodes into three fragments having mass in the ratio 2 : 2 : 1. If the fragments having equal mass fly off along mutually perpendicular directions with speed v , the speed of the third (lighter) fragment is :

- (1) $\sqrt{2}v$
- (2) $2\sqrt{2}v$
- (3) $3\sqrt{2}v$
- (4) v

19. If the initial tension on a stretched string is doubled, then the ratio of the initial and final speeds of a transverse wave along the string is :

- (1) $\sqrt{2} : 1$
- (2) $1 : \sqrt{2}$
- (3) $1 : 2$
- (4) $1 : 1$

20. An ideal gas undergoes four different processes from the same initial state as shown in the figure below. Those processes are adiabatic, isothermal, isobaric and isochoric. The curve which represents the adiabatic process among 1, 2, 3 and 4 is :

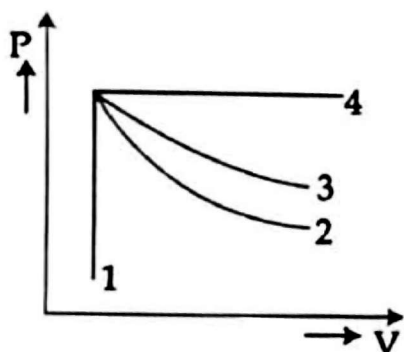

- (1) 2
- (2) 3
- (3) 4
- (4) 1

21. The angular speed of a fly wheel moving with uniform angular acceleration changes from 1200 rpm to 3120 rpm in 16 seconds. The angular acceleration in rad/s^2 is :

- (1) 4π
- (2) 12π
- (3) 104π
- (4) 2π

22. Plane angle and solid angle have :

- (1) Dimensions but no units
- (2) No units and no dimensions
- (3) Both units and dimensions
- (4) Units but no dimensions.

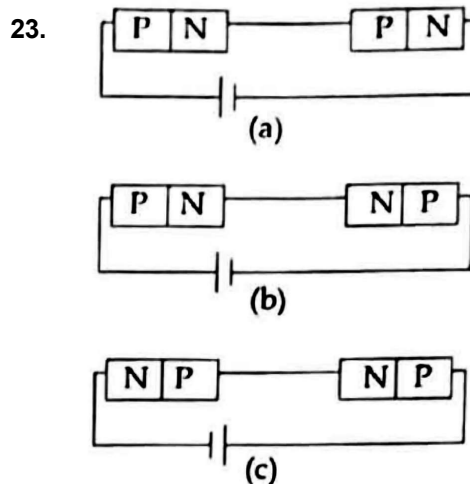

In the given circuits (a), (b) and (c), the potential drop across the two p-n junctions are equal in :

- (1) Circuit (b) only
- (2) Circuit (c) only
- (3) Both Circuit (a) and (c)
- (4) Circuit (a) only

24. In a Young's double slit experiment, a student observes 8 fringes in a certain segment of screen when a monochromatic light of 600 nm wavelength is used. If the wavelength of light is changed to 400 nm, then the number of fringes he would observe in the same region of the screen is:

- (1) 8
- (2) 9
- (3) 12
- (4) 6

25. When two monochromatic lights of frequency, ν and $\frac{\nu}{2}$ are incident on a photoelectric metal, their stopping potential becomes $\frac{V_s}{2}$ and V_s respectively. The threshold frequency for this metal is :
- (1) 3ν
 - (2) $\frac{2}{3}\nu$
 - (3) $\frac{3}{2}\nu$
 - (4) 2ν
26. A square loop of side 1 m and resistance 1Ω is placed in a magnetic field of 0.5 T. If the plane of loop is perpendicular to the direction of magnetic field, the magnetic flux through the loop is :
- (1) 0.5 weber
 - (2) 1 weber
 - (3) zero weber
 - (4) 2 weber
27. Two hollow conducting spheres of radii R_1 and R_2 ($R_1 \gg R_2$) have equal charges. The potential would be :
- (1) more on smaller sphere
 - (2) equal on both the spheres
 - (3) dependent on the material property of the sphere
 - (4) more on bigger sphere
28. A copper wire of length 10 m and radius $(10^{-2}/\sqrt{\pi})$ m has electrical resistance of 10Ω . The current density in the wire for an electric field strength of 10 (V/m) is :
- (1) 10^6 A/m²
 - (2) 10^{-5} A/m²
 - (3) 10^5 A/m²
 - (4) 10^4 A/m²
29. A long solenoid of radius 1 mm has 100 turns per mm. If 1 A current flows in the solenoid, the magnetic field strength at the centre of the solenoid is :
- (1) 12.56×10^{-2} T
 - (2) 12.56×10^{-4} T
 - (3) 6.28×10^{-4} T
 - (4) 6.28×10^{-2} T
30. Two objects of mass 10 kg and 20 kg respectively are connected to the two ends of a rigid rod of length 10 m with negligible mass. The distance of the center of mass of the system from the 10 kg mass is :
- (1) $\frac{20}{3}$ m
 - (2) 10 m
 - (3) 5 m
 - (4) $\frac{10}{3}$ m
31. A light ray falls on a glass surface of refractive index $\sqrt{3}$, at an angle 60° . The angle between the refracted and reflected rays would be :
- (1) 60°
 - (2) 90°
 - (3) 120°
 - (4) 30°
32. The dimensions $[MLT^{-2}A^{-2}]$ belong to the :
- (1) self inductance
 - (2) magnetic permeability
 - (3) electric permittivity
 - (4) magnetic flux.
33. The displacement-time graphs of two moving particles make angles of 30° and 45° with the x-axis as shown in the figure. The ratio of their respective velocity is :

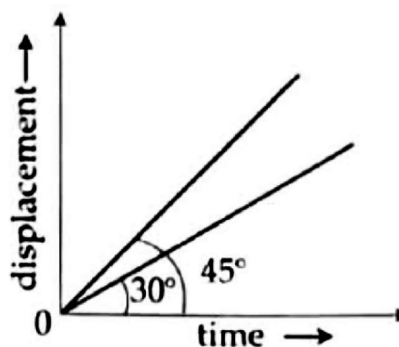

- (1) 1 : 1
- (2) 1 : 2
- (3) $1 : \sqrt{3}$
- (4) $\sqrt{3} : 1$

34. A biconvex lens has radii of curvature, 20 cm each. If the refractive index of the material of the lens is 1.5, the power of the lens is :

- (1) +20D
- (2) +5D
- (3) Infinity
- (4) +2D

35. Match List - I with List - II :

List - I (Electromagnetic waves)	List - II (Wavelength)
(a) AM radio waves	(i) 10^{-10} m
(b) Microwaves	(ii) 10^2 m
(c) Infrared radiations	(iii) 10^{-2} m
(d) X-rays	(iv) 10^{-4} m

Choose the correct answer from the options given below:

- (1) (a) - (iii), (b) - (ii), (c) - (i), (d) - (iv)
- (2) (a) - (iii), (b) - (iv), (c) - (ii), (d) - (i)
- (3) (a) - (ii), (b) - (iii), (c) - (iv), (d) - (i)
- (4) (a) - (iv), (b) - (iii), (c) - (ii), (d) - (i)

SECTION-B (Physics)

36. A nucleus of mass number 189 splits into two nuclei having mass number 125 and 64. The ratio of radius of two daughter nuclei respectively is :

- (1) 4 : 5
- (2) 5 : 4
- (3) 25 : 16
- (4) 1 : 1

37. Two transparent media A and B are separated by a plane boundary. The speed of light in those media are 1.5×10^8 m/s and 2.0×10^8 m/s, respectively. The critical angle for a ray of light for these two media is :

- (1) $\sin^{-1}(0.750)$
- (2) $\tan^{-1}(0.500)$
- (3) $\tan^{-1}(0.750)$
- (4) $\sin^{-1}(0.500)$

38. A big circular coil of 1000 turns and average radius 10 m is rotating about its horizontal diameter at 2 rad s^{-1} . If the vertical component of earth's magnetic field at that place is 2×10^{-5} T and electrical resistance of the coil is 12.56Ω , then the maximum induced current in the coil will be :

- (1) 1.5 A
- (2) 1 A
- (3) 2 A
- (4) 0.25 A

39. Match List - I with List - II :

List - I	List - II
(a) Gravitational constant (G)	(i) $[L^2T^{-2}]$
(b) Gravitational potential energy	(ii) $[M^{-1} L^3T^{-2}]$
(c) Gravitational potential	(iii) $[LT^{-2}]$
(d) Gravitational intensity	(iv) $[ML^2T^{-2}]$

Choose the correct answer from the options given below:

- (1) (a) - (ii), (b) - (iv), (c) - (i), (d) - (iii)
- (2) (a) - (ii), (b) - (iv), (c) - (iii), (d) - (i)
- (3) (a) - (iv), (b) - (ii), (c) - (i), (d) - (iii)
- (4) (a) - (ii), (b) - (i), (c) - (iv), (d) - (iii)

40. Given below are two statements : One is labelled as Assertion (A) and the other is labelled as Reason (R).

Assertion (A) :

The stretching of a spring is determined by the shear modulus of the material of the spring.

Reason (R) :

A coil spring of copper has more tensile strength than a steel spring of same dimensions. In the light of the above statements, choose the most appropriate answer from the options given below:

- (1) Both (A) and (R) are true and (R) is not the correct explanation of (A)
- (2) (A) is true but (R) is false
- (3) (A) is false but (R) is true
- (4) Both (A) and (R) are true and (R) is the correct explanation of (A).

41. The area of a rectangular field (in m^2) of length 55.3 m and breadth 25 m after rounding off the value for correct significant digits is :

- (1) 1382
- (2) 1382.5
- (3) 14×10^2
- (4) 138×10^1

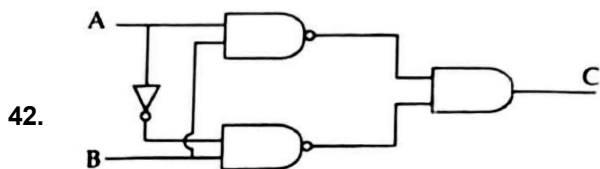

The truth table for the given logic circuit is :

(1)

A	B	C
0	0	1
0	1	0
1	0	0
1	1	1

(2)

A	B	C
0	0	1
0	1	0
1	0	1
1	1	0

(3)

A	B	C
0	0	0
0	1	1
1	0	0
1	1	1

(4)

A	B	C
0	0	0
0	1	1
1	0	1
1	1	0

43. The volume occupied by the molecules contained in 4.5 kg water at STP, if the intermolecular forces vanish away is :

- (1) $5.6 \times 10^3 \text{ m}^3$
- (2) $5.6 \times 10^{-3} \text{ m}^3$
- (3) 5.6 m^3
- (4) $5.6 \times 10^6 \text{ m}^3$

44. A wheatstone bridge is used to determine the value of unknown resistance X by adjusting the variable resistance Y as shown in the figure. For the most precise measurement of X, the resistance P and Q :

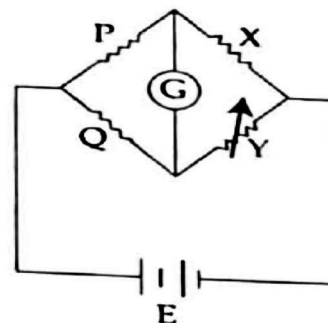

- (1) should be approximately equal and are small
- (2) should be very large and unequal
- (3) do not play any significant role
- (4) should be approximately equal to $2X$

45. A series LCR circuit with inductance 10 H, capacitance $10 \mu\text{F}$, resistance 50Ω is connected to an ac source of voltage, $V = 200 \sin(100 t)$ volt. If the resonant frequency of the LCR circuit is ν_0 and the frequency of the ac source is ν , then:

- (1) $\nu_0 = \nu = \frac{50}{\pi} \text{ Hz}$
- (2) $\nu_0 = \frac{50}{\pi} \text{ Hz}$, $\nu = 50 \text{ Hz}$
- (3) $\nu = 100 \text{ Hz}$, $\nu_0 = \frac{100}{\pi} \text{ Hz}$
- (4) $\nu_0 = \nu = 50 \text{ Hz}$.

46. A capacitor of capacitance $C = 900 \text{ pF}$ is charged fully by 100 V battery B as shown in figure (a). Then it is disconnected from the battery and connected to another uncharged capacitor of capacitance $C = 900 \text{ pF}$ as shown in figure (b). The electrostatic energy stored by the system (b) is:

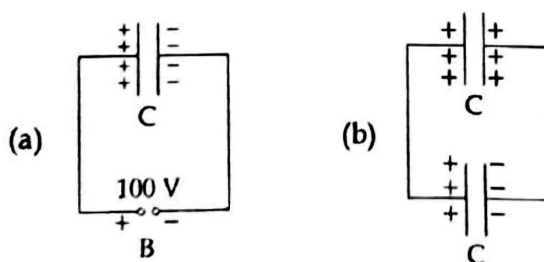

- (1) $3.25 \times 10^{-6} \text{ J}$
- (2) $2.25 \times 10^{-6} \text{ J}$
- (3) $1.5 \times 10^{-6} \text{ J}$
- (4) $4.5 \times 10^{-6} \text{ J}$

47. Two point charges $-q$ and $+q$ are placed at a distance of L , as shown in the figure.

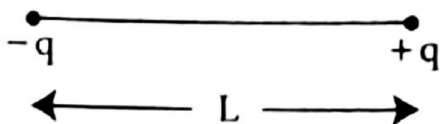

The magnitude of electric field intensity at a distance R ($R \gg L$) varies as :

- (1) $\frac{1}{R^3}$
- (2) $\frac{1}{R^4}$
- (3) $\frac{1}{R^6}$
- (4) $\frac{1}{R^2}$
48. A ball is projected with a velocity, 10 ms^{-1} , at an angle of 60° with the vertical direction. Its speed at the highest point of its trajectory will be :
- (1) $5\sqrt{3} \text{ ms}^{-1}$
- (2) 5 ms^{-1}
- (3) 10 ms^{-1}
- (4) zero

49. From Ampere's circuital law for a long straight wire of circular cross-section carrying a steady current, the variation of magnetic field in the inside and outside region of the wire is :

- (1) a linearly increasing function of distance upto the boundary of the wire and then linearly decreasing for the outside region.
- (2) a linearly increasing function of distance r upto the boundary of the wire and then decreasing one with $1/r$ dependence for the outside region.
- (3) a linearly decreasing function of distance upto the boundary of the wire and then a linearly increasing one for the outside region
- (4) uniform and remains constant for both the regions.
50. Two pendulums of length 121 cm and 100 cm start vibrating in phase. At some instant, the two are at their mean position in the same phase. The minimum number of vibrations of the shorter pendulum after which the two are again in phase at the mean position is :

- (1) 9
- (2) 10
- (3) 8
- (4) 11

SECTION-A

51. The given graph is a representation of kinetics of a reaction.

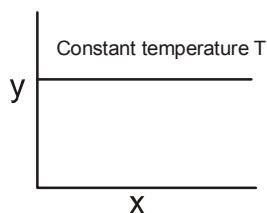

The y and x axes for zero and first order reactions, respectively are

- (1) zero order (y = concentration and x = time), first order (y = rate constant and X = concentration)
- (2) zero order (y = rate and x = concentration), first order (y = $t_{1/2}$, and x = concentration)
- (3) zero order (y = rate and x = concentration), first order (y = rate and x = $t_{1/2}$)
- (4) zero order (y = concentration and x = time), first order (y = $t_{1/2}$ and x = concentration)

52. Which compound amongst the following is not an aromatic compound

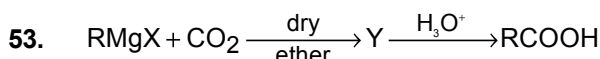
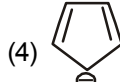
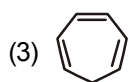
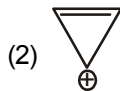
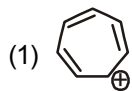

What is Y in the above reaction :

- (1) $\text{R}_3\text{CO}^- \text{Mg}^+ \text{X}$
 - (2) $\text{RCOO}^- \text{X}^+$
 - (3) $(\text{RCOO})_2\text{Mg}$
 - (4) $\text{RCOO}^- \text{Mg}^+ \text{X}$
54. Which of the following statement is not correct about diborane?
- (1) The four terminal B-H bonds are two centre two electron bonds.
 - (2) The four terminal Hydrogen atoms and the two Boron atoms lie in one plane.
 - (3) Both the Boron atoms are sp^2 - hybridised.
 - (4) There are two 3-centre-2-electron bonds

55. Gadolinium has a low value of third ionisation enthalpy because of

- (1) high exchange enthalpy
- (2) high electronegativity
- (3) high basic character
- (4) small size

56. Which one is not correct mathematical equation for Dalton's Law of partial pressure? Here p = total pressure of gaseous mixture

(1) $p = n_1 \frac{RT}{V} + n_2 \frac{RT}{V} + n_3 \frac{RT}{V}$

(2) $p_i = x_i p$, where p_i = partial pressure of i^{th} gas x_i = mole fraction of i^{th} gas in gaseous mixture

(3) $p_i = x_i p_i^\circ$, where x_i = mole fraction of i^{th} gas in gaseous mixture p_i° = pressure of i^{th} gas in pure state

(4) $p = p_1 + p_2 + p_3$

57. Given below are two statements :

Statement I:

The boiling points of the following hydrides of group 16 elements increases in the order -

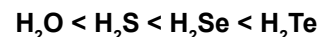

Statement II :

The boiling points of these hydrides increase with increase in molar mass.

In the light of the above statements, choose the most appropriate answer from the options given below :

- (1) Both Statement 1 and Statement II are incorrect
- (2) Statement I is correct but Statement II is incorrect
- (3) Statement I is incorrect but Statement II is correct
- (4) Both Statement I and Statement II are correct.

58. Given below are two statements :

Statement I :

The acidic strength of monosubstituted nitrophenol is higher than phenol because of electron withdrawing nitro group,

Statement II :

o-nitrophenol, *m*-nitrophenol and *p*-nitrophenol will have same acidic strength as they have one nitro group attached to the phenolic ring.

In the light of the above statements, choose the most appropriate answer from the options given below :

- (1) Both Statement I and Statement II are incorrect
- (2) Statement I is correct but Statement II is incorrect.
- (3) Statement I is incorrect but Statement II is correct.
- (4) Both Statement I and Statement II are correct.

59. The Kjeldahl's method for the estimation of nitrogen can be used to estimate the amount of nitrogen in which one of the following compounds:

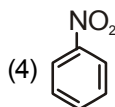
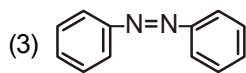
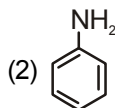
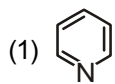

60. Match List-I with List-II,

List-I

List-II

(Drug Class)

(Drug molecule)

- | | |
|-------------------|-----------------|
| a. Antacids | i. Salvarsan |
| b. Antihistamines | ii. Morphine |
| c. Analgesics | iii. Cimetidine |
| d. Antimicrobials | iv. Seldane |

Choose the correct answer from the options given below

- (1) a-iii, b-iv, c-ii, d-i (2) a-i, b-iv, c-ii, d-iii
 (3) a-iv, b-iii, c-i, d-ii (4) a-iii, b-ii, c-iv, d-i

61. The IUPAC name of an element with atomic number 119 is :

- (1) unnilennium (2) unununnium
 (3) ununoctium (4) ununennium

62. Amongst the following which one will have maximum 'lone pair - lone pair' electron repulsions :

- (1) IF_5 (2) SF_4
 (3) XeF_2 (4) ClF_3

63. Which of the following sequence of reactions is suitable to synthesize chlorobenzene :

- (1) Phenol, NaNO_2 , HCl , CuCl

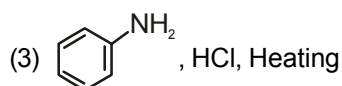
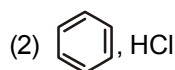

- (4) Benzene, Cl_2 , anhydrous FeCl_3

64. Which of the following p-V curve represents maximum work done?

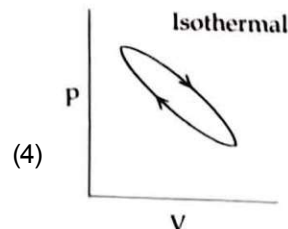
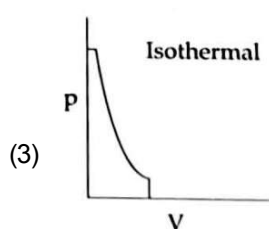
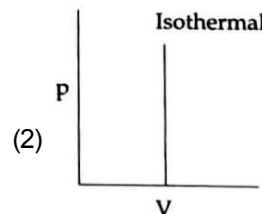
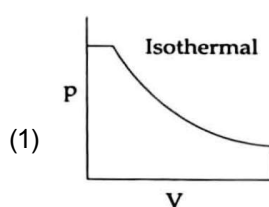

65. Given below are half cell reactions :



$$E_{\text{Mn}^{2+}/\text{MnO}_4^-}^{\circ} = -1.510 \text{ V}$$

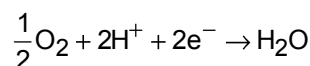

$$E_{\text{O}_2/\text{H}_2\text{O}}^{\circ} = +1.223 \text{ V}$$

Will the permanganate ion, MnO_4^- liberate O_2 from water in the presence of an acid ?

- (1) No, because $E_{\text{cell}}^{\circ} = -0.287 \text{ V}$
 (2) Yes, because $E_{\text{cell}}^{\circ} = +2.733 \text{ V}$
 (3) No, because $E_{\text{cell}}^{\circ} = -2.733 \text{ V}$
 (4) Yes, because $E_{\text{cell}}^{\circ} = +0.287 \text{ V}$

66. The IUPAC name of the complex -

$[\text{Ag}(\text{H}_2\text{O})_2][\text{Ag}(\text{CN})_2]$ is :

- (1) diaquasilver(II) dicyanidoargentate(II)
 (2) dicyanidosilver(I) diaquaargentate(I)
 (3) diaquasilver(I) dicyanidoargentate(I)
 (4) dicyanidosilver(II) diaquaargentate(II)

67. Identify the incorrect statement from the following :

- (1) The oxidation number of K in KO_2 is +4
 (2) Ionisation enthalpy of alkali metals decreases from top to bottom in the group.
 (3) Lithium is the strongest reducing agent among the alkali metals.
 (4) Alkali metals react with water to form their hydroxides

68. What mass of 95% pure CaCO_3 will be required to neutralise 50 mL of 0.5 M HCl solution according to the following reaction

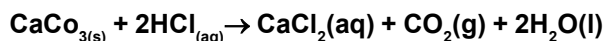

[Calculate upto second place of decimal point]

- (1) 1.32 g (2) 3.65 g
(3) 9.50 g (4) 1.25 g
69. Given below are two statements :
Statements I :
Primary aliphatic amines react with HNO_2 to give unstable diazonium salts.
Statements II :
Primary aromatic amines react with HNO_2 to form diazonium salts which are stable even above 300 K.
In the light of the above statements, choose the most appropriate answer from the options given below :
- (1) Both Statement I and Statement II are incorrect.
(2) Statement I is correct but Statement II is incorrect
(3) Statement I is incorrect but Statement II is correct
(4) Both Statement I and Statement II are correct
70. Which statement regarding polymers is not correct?
- (1) Fibers possess high tensile strength.
(2) Thermoplastic polymers are capable of repeatedly softening and hardening on heating and cooling respectively.
(3) Thermosetting polymers are reusable.
(4) Elastomers have polymer chains held together by weak intermolecular forces
71. The incorrect statement regarding chirality is :
- (1) The product obtained by $\text{S}_{\text{N}}2$ reaction of haloalkane having chirality at the reactive site shows inversion of configuration.
(2) Enantiomers are superimposable mirror images on each other.
(3) A racemic mixture shows zero optical rotation.
(4) $\text{S}_{\text{N}}1$ reaction yields 1 : 1 mixture of both enantiomers.
72. Given below are two statements :
Statement I :
In the coagulation of a negative sol, the flocculating power of the three given ions is in the order -
 $\text{Al}^{3+} > \text{Ba}^{2+} > \text{Na}^+$
Statement II :
In the coagulation of a positive sol, the flocculating power of the three given salts is in the order -
 $\text{NaCl} > \text{Na}_2\text{SO}_4 > \text{Na}_3\text{PO}_4$
In the light of the above statements, choose the most appropriate answer from the options given below :
- (1) Both Statement I and Statement II are incorrect.
(2) Statement I is correct but Statement II is incorrect.
(3) Statement I is incorrect but Statement II is correct.
(4) Both Statement I and Statement II are correct.

73. List-I (Hydrides)
- (a) MgH_2
(b) GeH_4
(c) B_2H_6
(d) HF
- List-II (Nature)
- (i) Electron precise
(ii) Electron deficient
(iii) Electron rich
(iv) Ionic
- Choose the correct answer from the options given below:
- (1) (a)- (iii), (b)- (i), (c)- (ii), (d)- (iv)
(2) (a)- (i), (b)- (ii), (c)- (iv), (d)- (iii)
(3) (a)- (ii), (b)- (iii), (c)- (iv), (d)- (i)
(4) (a)- (iv), (b)- (i), (c)- (ii), (d)- (iii)
74. Match List-I with List-II :
- | List-I | List-II |
|---------|--|
| (a) Li | (i) absorbent for carbon dioxide |
| (b) Na | (ii) electrochemical cells |
| (c) KOH | (iii) coolant in fast breeder reactors |
| (d) Cs | (iv) photoelectric cell |
- Choose the correct answer from the options given below:
- (1) (a)- (iii), (b)- (v), (c)- (ii), (d)- (i)
(2) (a)- (i), (b)- (iii), (c)- (iv), (d)- (ii)
(3) (a)- (ii), (b)- (iii), (c)- (i), (d)- (iv)
(4) (a)- (iv), (b)- (i), (c)- (iii), (d)- (ii)
75. Given below are two statements: one is labelled as Assertion(A) and the other is labelled as Reason (R).
- Assertion(A):**
In a particular point defect, an ionic solid is electrically neutral, even if few of its cations are missing from its unit cells.
- Reason(R):**
In an ionic solid, Frenkel defect arises due to dislocation of cation from its lattice site to interstitial site, maintaining overall electrical neutrality.
- In the light of the above statements, choose the most appropriate answer from the options given below:
- (1) Both (A) and (R) are correct but (R) is not the correct explanation of (A)
(2) (A) is correct but (R) is not correct
(3) (A) is not correct but (R) is correct
(4) Both (A) and (R) are correct and (R) is the correct explanation of (A)

76. The incorrect statement regarding enzymes is :
- (1) Like chemical catalysts enzymes reduce the activation energy of bio processes.
 - (2) Enzymes are polysaccharides.
 - (3) Enzymes are very specific for a particular reaction and substrate.
 - (4) Enzymes are biocatalysts.
77. Match List-I with List-II :
- | List-I | (List-II) |
|-------------------|--------------------------------------|
| (Products formed) | (Reaction of carbonyl compound with) |
| (a) Cyanohydrin | (i) NH_2OH |
| (b) Acetal | (ii) RNH_2 |
| (c) Schiff's base | (iii) alcohol |
| (d) Oxime | (iv) HCN |
- Choose the correct answer from the options given below:
- (1) (a)- (ii), (b)- (iii), (c)- (iv), (d)- (i)
 - (2) (a)- (i), (b)- (iii), (c)- (ii), (d)- (iv)
 - (3) (a)- (iv), (b)- (iii), (c)- (ii), (d)- (i)
 - (4) (a)- (iii), (b)- (iv), (c)- (ii), (d)- (i)
78. In one molal solution that contains 0.5 mole of a solute, there is :
- (1) 500 g of solvent
 - (2) 100 mL of solvent
 - (3) 1000 g of solvent
 - (4) 500 mL of solvent
79. Choose the correct statement :
- (1) Diamond is covalent and graphite is ionic.
 - (2) Diamond is sp^3 hybridised and graphite is sp^2 hybridized.
 - (3) Both diamond and graphite are used as dry lubricants.
 - (4) Diamond and graphite have two dimensional network.
80. Which amongst the following is incorrect statement:
- (1) C_2 molecule has four electrons in its two degenerate π molecular orbitals.
 - (2) H_2^+ ion has one electron.
 - (3) O_2^+ ion is diamagnetic.
 - (4) The bond orders of O_2^+ , O_2 , O_2^- and O_2^{2-} are 2.5, 2, 1.5 and 1, respectively.
81. Given below are two statements: one is labelled as :
- Assertion(A):** ICl is more reactive than I_2
- Reason(R):** I-Cl bond is weaker than I-I bond.
- In the light of the above statements, choose the most appropriate answer from the options given below:
- (1) Both(A) and (R) are correct but (R) is not the correct explanation of (A).
 - (2) (A) is correct but (R) is not correct.
 - (3) (A) is not correct but (R) is correct.
 - (4) Both(A) and (R) are correct and (R) is the correct explanation of (A).
82. Given below are two statements:
- The boiling points of aldehydes and ketones are higher than hydrocarbons of comparable molecular masses because of weak molecular association in aldehydes and ketones due to dipole - dipole interactions.**
- Statement II :**
- The boiling points of aldehydes and ketones are lower than the alcohols of similar molecular masses due to the absence of H-bonding.**
- In the light of the above statements, choose the most appropriate answer from the options given below:
- (1) Both Statement I and Statement II are incorrect.
 - (2) Statement I is correct but Statement II is incorrect
 - (3) Statement I is incorrect but Statement II is correct
 - (4) Both Statement I and Statement II are correct.
83. The pH of the solution containing 50 mL each of 0.10 M sodium acetate and 0.01 M acetic acid is [Given pK_a of $\text{CH}_3\text{COOH} = 4.57$] :
- (1) 3.57
 - (2) 4.57
 - (3) 2.57
 - (4) 5.57
84. Identify the incorrect statement from the following:
- (1) All the five 4d orbitals have shapes similar to the respective 3d orbitals.
 - (2) In an atom, all the five 3d orbitals are equal in energy in free state.
 - (3) The shapes of d_{xy} , d_{yz} , and d_{zx} orbitals are similar to each other; and $d_{x^2-y^2}$ and d_{x^2} are similar to each other.
 - (4) All the five 5d orbitals are different in size when compared to the respective 4d orbitals.

85. At 298K, the standard electrode potentials of Cu^{2+}/Cu , Zn^{2+}/Zn , Fe^{2+}/Fe and Ag^+/Ag are 0.34 V, -0.76 V, -0.44 V and 0.80 V, respectively.

On the basis of standard electrode potential, predict which of the following reaction can not occur :

- (1) $\text{CuSO}_4(\text{aq}) + \text{Fe}(\text{s}) \rightarrow \text{FeSO}_4(\text{aq}) + \text{Cu}(\text{s})$
- (2) $\text{FeSO}_4(\text{aq}) + \text{Zn}(\text{s}) \rightarrow \text{ZnSO}_4(\text{aq}) + \text{Fe}(\text{s})$
- (3) $2\text{CuSO}_4(\text{aq}) + 2\text{Ag}(\text{s}) \rightarrow 2\text{Cu}(\text{s}) + \text{Ag}_2\text{SO}_4(\text{aq})$
- (4) $\text{CuSO}_4(\text{aq}) + \text{Zn}(\text{s}) \rightarrow \text{ZnSO}_4(\text{aq}) + \text{Cu}(\text{s})$

SECTION-B

86. The order of energy absorbed which is responsible for the color of complexes:

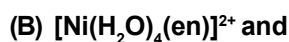
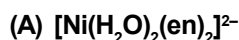

is

- (1) (C) > (B) > (A) (2) (C) > (A) > (B)
- (3) (B) > (A) > (C) (4) (A) > (B) > (C)

87. A 10.0 L flask contains 64 g of oxygen at 27°C. (Assume O_2 gas is behaving ideally). The pressure inside the flask in bar is :

(Given $R = 0.0831 \text{ L bar K}^{-1}$)

- (1) 498.6 (2) 49.8
- (3) 4.9 (4) 2.5

88. Which one of the following is not formed when acetone reacts with 2-pentanone in the presence of dilute NaOH followed by heating :

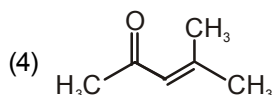
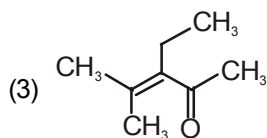
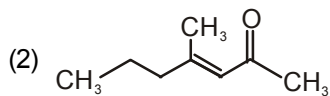
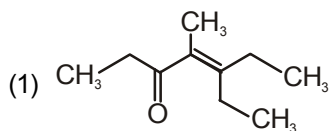

89. Find the emf of the cell in which the following reaction takes place at 298 K

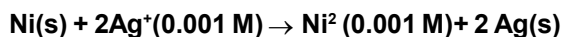

(Given that $E^\circ_{\text{cell}} = 10.5 \text{ V}$, $\frac{2.303 RT}{F} = 0.059$ at

298 K)

- (1) 1.385 V (2) 0.9615 V
- (3) 1.05 V (4) 1.0385 V

90. The product formed from the following reaction sequence is :

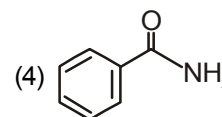
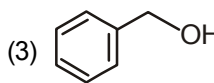
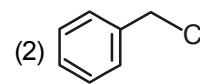
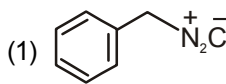
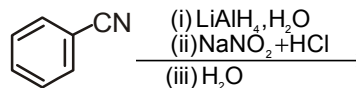

91. Copper crystallises in fcc unit cell with cell edge length of $3.608 \times 10^{-8} \text{ cm}$. The density of copper is 8.92 g cm^{-3} . Calculate the atomic mass of copper.

- (1) 31.55 u (2) 60 u³¹
- (3) 65 u¹ (4) 63.1 u

92. $3\text{O}_2(\text{g}) \rightleftharpoons 2\text{O}_3(\text{g})$

For the above reaction at 298 K, K_c is found to be 3.0×10^{-59} . If the concentration of O_2 at equilibrium is 0.040 M then concentration of O_3 in M is :

- (1) 1.9×10^{-63} (2) 2.4×10^{31}
- (3) 1.2×10^{21} (4) 4.38×10^{-32}

93. Given below are two statements :

Statement I :

In Lucas test, primary, secondary and tertiary alcohols are distinguished on the basis of their reactivity with conc. HCl + ZnCl_2 , known as Lucas Reagent.

Statement II :

Primary alcohols are most reactive and immediately produce turbidity at room temperature on reaction with Lucas Reagent.

In the light of the above statements, choose the most appropriate answer from the options given below:

- (1) Both Statement I and Statement II are incorrect.
- (2) Statement I is correct but Statement I is incorrect
- (3) Statement I is incorrect but Statement II is correct.
- (4) Both Statement I and Statement II are correct.

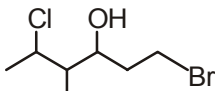
94. In the neutral or faintly alkaline medium, KMnO_4 oxidises iodide into iodate. The change in oxidation state of manganese in this reaction is from :
- (1) +6 to +4 (2) +7 to +3
 (3) +6 to +5 (4) +7 to +4
95. Match List - I with List - II.
- | List - I | List - II |
|---------------|--|
| (Ores) | (Composition) |
| (a) Haematite | (i) Fe_3O_4 |
| (b) Magnetite | (ii) ZnCO_3 |
| (c) Calamine | (iii) Fe_2O_3 |
| (d) Kaolinite | (iv) $[\text{Al}_2(\text{OH})\text{Si}_2\text{O}_5]$ |
- Choose the correct answer from the options given below :
- (1) (a) - (iii), (b) - (i), (c) - (ii), (d) - (iv)
 (2) (a) - (iii), (b) - (i), (c) - (iv), (d) - (ii)
 (3) (a) - (i), (b) - (iii), (c) - (ii), (d) - (iv)
 (4) (a) - (i), (b) - (ii), (c) - (iii), (d) - (iv)
96. The correct IUPAC name of the following compound is
- 
- (1) 6-bromo-2-chloro-1-methylhexan-1-ol
 (2) 1-bromo-4-methyl-5-chlorohexan-3-ool
 (3) 6-bromo-4-methyl-2-chlorohexan-4-ol
 (4) 1-bromo-5-chloro-4-methylhexan-3-ol
97. If radius of second Bohr orbit of the He^+ ion is 105.8 pm, what is the radius of third Bohr orbit of Li^{2+}
- (1) 15.87 pm (2) 1.587 pm
 (3) 158.7 Å (4) 158.7 pm
98. Compound X on reaction with O_3 followed by $\text{Zn}/\text{H}_2\text{O}$ gives formaldehyde and 2-methyl propanal as products. The compound X is :
- (1) 2-Methylbut-1-ene (2) 2-Methylbut-2-ene
 (3) Pent-2-ene (4) 3-Methylbut-1-ene
99. For a first order reaction $\text{A} \rightarrow \text{Products}$, initial concentration of A is 0.1 M, which becomes 0.001 M after 5 minutes. Rate constant for the reaction in min^{-1} is
- (1) 0.9212 (2) 0.4606
 (3) 0.2303 (4) 1.3818
100. The pollution due to oxides of sulphur gets enhanced due to the presence of:
- (a) particulate matter
 (b) ozone
 (c) hydrocarbons
 (d) hydrogen peroxide
- Choose the most appropriate answer from the options given below:
- (1) (a), (b), (d) only (2) (b), (c), (d) only
 (3) (a), (c), (d) only (4) (a), (d) only



Section - A (Biology: Botany)

101. Which of the following is not a method of ex situ conservation?

- (1) National Parks
- (2) Micropropagation
- (3) Cryopreservation
- (4) In vitro fertilization

102. Given below are two statements :

Statement I :

The primary CO_2 acceptor in C_4 plants is phosphoenolpyruvate and is found in the mesophyll cells.

Statement II :

Mesophyll cells of C_4 plants lack RuBisCo enzyme. In the light of the above statements, choose the correct answer from the options given below

- (1) Both Statement I and Statement II are incorrect
- (2) Statement I is correct but Statement II is incorrect
- (3) Statement I is incorrect but Statement II is correct
- (4) Both, Statement I and Statement are correct

103. XO type of sex de termination can be found in :

- (1) Birds
- (2) Grasshoppers
- (3) Monkeys
- (4) Drosophila

104. In old trees the greater part of secondary xylem is dark brown and resistant to insect attack due to :

- (a) secretion of secondary metabolities and ilieir deposition in ilie lumen of vessels.
- (b) deposition of organic compounds like tannins and resins in ilie central layers of stem.
- (c) deposition of s uberin and a romatic substances in ilie outer layer of stem.
- (d) deposition of tannins, gum, resin and aromatic substances in ilie peripheral layers of stem.
- (e) presence of parenchyma cells, functionally active xylem elements and essential oils.

Choose ilie correct answer from the options given below:

- (1) (c) and (d) Only
- (2) (d) and (e) Only
- (3) (b) and (d) Only
- (4) (a) and (b) Only

105. Which of the following is not observed during apoplastic pathway ?

- (1) The movement does not involve crossing of cell membrane
- (2) The movement is aided by cytoplasmic streaming
- (3) Apoplast is continuous and does not provide any barrier to water movement
- (4) Movement of water occurs through intercellular spaces and wall of the cells

106. Given below are two statements : one is labelled as Assertion (A) and the other is labelled as Reason (R)
- Assertion (A)**
- Polymerase chain reaction is used in DNA amplification
- Reason (R)**
- The ampicillin resistant gene is used as a selectable marker to check transformation
- In the light of the above statements, choose the correct answer from the options given below :
- (1) Both (A) and (R) are correct but (R) is not the correct explanation of (A)
 - (2) (A) is correct but (R) is not correct
 - (3) (A) is not correct but (R) is correct
 - (4) Both (A) and (R) are correct and (R) is the correct explanation of (A)
107. Which one of the following statement is not true regarding gel electrophoresis technique ?
- (1) The separated DNA fragments are stained by using ethidium bromide
 - (2) The presence of chromogenic substrate gives blue coloured DNA bands on the gel
 - (3) Bright orange coloured bands of DNA can be observed in the gel when exposed to UV light
 - (4) The process of extraction of separated DNA strands from gel is called elution
108. The gaseous plant growth regulator is used in plants to :
- (1) Promote root growth and root hair formation to increase the absorption surface
 - (2) Help overcome apical dominance
 - (3) Kill dicotyledonous weeds in the fields
 - (4) Speed up the malting process
109. What amount of energy is released from glucose during lactic acid fermentation ?
- (1) More than 18%
 - (2) About 10%
 - (3) Less than 7%
 - (4) Approximately 15%
110. Read the following statements about the vascular bundles :
- (a) In roots, xylem and phloem in a vascular bundle are arranged in an alternate manner along the different radii
 - (b) Conjoint closed vascular bundles do not process cambium
 - (c) In open vascular bundles, cambium is present in between xylem and phloem
 - (d) The vascular bundles of dicotyledonous stem possess endarch protoxylem
 - (e) In monocotyledonous root, usually there are more than six xylem bundles present
- (1) (b), (c) (d) and (e) only
 - (2) (a), (b), (c) and (d) only
 - (3) (a), (c), (d) and (e) only
 - (4) (a), (b) and (d) only
111. Identify the correct set of statements
- (a) The leaflets are modified into pointed hard thorns in Citrus and Bougainvillea
 - (b) Axillary buds form slender and spirally coiled tendrils in cucumber and pumpkin
 - (c) Stem is flattened and fleshy in Opuntia and modified to perform the function of leaves
 - (d) Rhizophora shows vertically upward growing roots that help to get oxygen for respiration
 - (e) Subaerially growing stems in grasses and strawberry help in vegetative propagation
- Choose the correct answer from the options given below:
- (1) (a) and (d) only
 - (2) (b), (c), (d) and (e) only
 - (3) (a), (b), (d) and (e) only
 - (4) (b) and (c) only
112. Which one of the following plants does not show plasticity ?
- (1) Coriander
 - (2) Buttercup
 - (3) Maize
 - (4) Cotton

113. Given below are two statements

Statement I :

Cleistogamous flowers are invariably autogamous

Statement II :

Cleistogamy is disadvantageous as there is no chance for cross pollination

In the light of the above statements, choose the correct answer from the options given below

- (1) Both statement I and statement II are incorrect
- (2) Statement I is correct but statement II is incorrect
- (3) Statement I is incorrect but statement II is correct
- (4) Both statement I and statement II are correct

114. "Girdling Experiment" was performed by Plant Physiologists to identify the plant tissue through which :

- (1) Food is transported
- (2) For both water and food transportation
- (3) Osmosis is observed
- (4) Water is transported

115. Hydrocolloid carrageen is obtained from :

- (1) Phaeophyceae and Rhodophyceae
- (2) Rhodophyceae only
- (3) Phaeophyceae only
- (4) Chlorophyceae and Phaeophyceae

116. Given below are two statements :

Statement I :

Mendel studied seven pairs of contrasting traits in pea plants and proposed the Laws of Inheritance

Statement II :

Seven characters examined by Mendel in his experiment on pea plants were seed shape and colour, flower colour, pod shape and colour, flower position and stem height

In the light of the above statements, choose the correct answer from the options given below :

- (1) Both Statement I and Statement II are incorrect
- (2) Statement I is correct but Statement II is incorrect
- (3) Statement I is incorrect but Statement II is correct
- (4) Both Statement I and Statement II are correct

117. Production of Cucumber has increased manifold in recent years. Application of which of the following phytohormones has resulted in this increased yield as the hormone is known to produce female flowers in the plants :

- (1) Gibberellin
- (2) Ethylene
- (3) Cytokinin
- (4) ABA

118. The process of translation of mRNA to proteins begins as soon as :

- (1) The larger subunit of ribosome encounters mRNA
- (2) Both the subunits join together to bind with mRNA
- (3) The tRNA is activated and the larger subunit of ribosome encounters mRNA
- (4) The small subunit of ribosome encounters mRNA

119. Habitat loss and fragmentation, over exploitation alien species invasion and co-extinction are causes for :

- (1) Competition
- (2) Biodiversity loss
- (3) Natality
- (4) Population explosion

120. Read the following statements and choose the set of correct statements :

- (a) Euchromatin is loosely packed chromatin
- (b) Heterochromatin is transcriptionally active
- (c) Histone octamer is wrapped by negatively charged DNA in nucleosome
- (d) Histones are rich in lysine and arginine
- (e) A typical nucleosome contains 400 bp of DNA helix

Choose the correct answer from the options given below

- (1) (a), (c), (d) only
- (2) (b), (e) only
- (3) (a), (c), (e) only
- (4) (b), (d), (e) only

121. Which of the following is incorrectly matched ?

- (1) Ulothrix – Mannitol
- (2) Porphyra – Floridian Starch
- (3) Volvox – Starch
- (4) Ectocarpus – Fucoxanthin

122. The device which can remove particulate matter present in the exhaust from a thermal power plant is :
- (1) Incinerator
 - (2) Electrostatic Precipitator
 - (3) Catalytic Converter
 - (4) STP
123. DNA polymorphism forms the basis of
- (1) DNA finger printing
 - (2) Both genetic mapping and DNA finger printing
 - (3) Translation
 - (4) Genetic mapping
124. Which one of the following statements cannot be connected to Predation ?
- (1) It might lead to extinction of a species
 - (2) Both the interacting species are negatively impacted
 - (3) It is necessitated by nature to maintain the ecological balance
 - (4) It helps in maintaining species diversity in a community
125. Which one of the following never occurs during mitotic cell division ?
- (1) Movement of centrioles towards opposite poles
 - (2) Pairing of homologous chromosomes
 - (3) Coiling and condensation of the chromatids
 - (4) Spindle fibres attach to kinetochores of chromosomes
126. Exoskeleton of arthropods is composed of
- (1) Cellulose
 - (2) Chitin
 - (3) Glucosamine
 - (4) Cutin
127. What is the net gain of ATP when each molecule of glucose is converted to two molecules of pyruvic acid ?
- (1) Six
 - (2) Two
 - (3) Eight
 - (4) Four
128. Which one of the following plants shows vexillary aestivation and diadelphous stamens ?
- (1) *Pisum sativum*
 - (2) *Allium cepa*
 - (3) *Solanum nigrum*
 - (4) *Colchicum autumnale*
129. Identify the incorrect statement related to Pollination :
- (1) Pollination by wind is more common amongst abiotic pollination
 - (2) Flowers produce foul odours to attract flies and beetles to get pollinated
 - (3) Moths and butterflies are the most dominant pollinating agents among insects
 - (4) Pollination by water is quite rare in flowering plants
130. Given below are two statements :
- Statement I :**
Decomposition is a process in which the detritus is degraded into simpler substances by microbes
- Statement II :**
Decomposition is faster if the detritus is rich in lignin and chitin
- In the light of the above statements, choose the correct answer from the options given below
- (1) Both Statement I and Statement II are incorrect
 - (2) Statement I is correct but Statement II is incorrect
 - (3) Statement I is incorrect but Statement II is correct
 - (4) Both Statement I and Statement II are correct
131. The appearance of recombination nodules on homologous chromosomes during meiosis characterizes :
- (1) Bivalent
 - (2) Sites at which crossing over occurs
 - (3) Terminalization
 - (4) Synaptonemal complex
132. Which one of the following produces nitrogen fixing nodules on the roots of *Alnus* ?
- (1) *Frankia*
 - (2) *Rhodospirillum*
 - (3) *Beijerinckia*
 - (4) *Rhizobium*

133. Which one of the following is not true regarding the release of energy during ATP synthesis through chemiosmosis ? It involves

- (1) Breakdown of electron gradient
- (2) Movement of protons across the membrane to the stroma
- (3) Reduction of NADP to NADPH₂ on the stroma side of the membrane
- (4) Breakdown of proton gradient

134. The flowers are Zygomorphic in

- (a) Mustard
- (b) Glumohar
- (c) Cassia
- (d) Datura
- (e) Chilly

Choose the correct answer from the options given below

- (1) (b), (c) only
- (2) (d), (e) only
- (3) (c), (d), (e) only
- (4) (a), (b), (c) only

135. Match List - I with List - II

List - I	List - II
(a) Manganese	(i) Activates the enzyme catalase
(b) Magnesium	(ii) Required for pollen germination
(c) Boron	(iii) Activates enzymes of respiration
(d) Iron	(iv) Functions in splitting of water during photosynthesis

Chose the correct answer from the option given below

- (1) (a) - (iv), (b) - (iii), (c) - (ii), (d) - (i)
- (2) (a) - (iv), (b) - (i), (c) - (ii), (d) - (iii)
- (3) (a) - (iii), (b) - (i), (c) - (ii), (d) - (iv)
- (4) (a) - (iii), (b) - (iv), (c) - (i), (d) - (ii)

SECTION-B (Biology: Botany)

136. Addition of solutes in a given solution will :

- (1) lower its water potential
- (2) make its water
- (3) not affect the water potential at all
- (4) raise its water potential

137. Read the following statements on lipids and find out correct set of statements.

- (a) Lecithin found in the plasma membrane is a glycolipid
- (b) Saturated fatty acids possess one or more c =c bonds
- (c) Gingely oil has lower meting point, hence remains as oil in winter
- (d) Lipids are generally insoluble in water but soluble in some organic solvents
- (e) When fatty acid is esterified with glycerol, monoglycerides are formed

Choose the correct answer from the options given below:

- (1) (a),(d) and (e) only
- (2) (c),(d) and (e) only
- (3) (a),(b) and (d) only
- (4) (a),(b) and (c) only

138. What is the role of large bundle sheath cells found around the vascular bundles in C₄ plants :

- (1) To increase the number of chloroplast for the operation of Calvin cycle
- (2) To enable the plant to tolerate high temperature
- (3) To protect the vascular tissue from high light intensity
- (4) To provide the site for photorespiratory pathway

139. The entire fleet of buses in Delhi were converted to CNG from diesel. In reference to this, which one of the following statements in false ?

- (1) The same diesel engine is used in CNG buses making the cost of conversion low
- (2) It is cheaper than diesel
- (3) It can not be adulterated like diesel
- (4) CNG burns more efficiently than diesel

140. Transposons can be used during which one of the following ?

- (1) Gene silencing
- (2) Autoradiography
- (3) Gene sequencing
- (4) Polymerase Chain Reaction

141. Match List-I with List-II.

- | List - I | List - II |
|----------------------------|---|
| (a) Metacentric chromosome | (i) Centromere situated close to the end forming one extremely short and one very long arms |
| (b) Acrocentric Chromosome | (ii) Centromere at the terminal end |
| (c) Sub-metacentric | (iii) Centromere in the middle forming one shorter arm and one longer arm |
| (d) Telocentric chromosome | (iv) Centromere slightly away from the middle forming one shorter arm and one longer arm |

- (1) (a) - (i), (b) - (iii), (c) - (ii), (d) - (iv)
 (2) (a) - (ii), (b) - (iii), (c) - (iv), (d) - (i)
 (3) (a) - (i), (b) - (ii), (c) - (iii), (d) - (iv)
 (4) (a) - (iii), (b) - (i), (c) - (iv), (d) - (ii)

142. Match the plant with the kind of life cycle it exhibits :

- | List - I | List - II |
|---------------|---|
| (a) Spirogyra | (i) Dominant diploid sporophyte vascular plant, with highly reduced male or female gametophyte |
| (b) Fern | (ii) Dominant haploid free-living gametophyte |
| (c) Funaria | (iii) Dominant diploid sporophyte alternating with reduced gametophyte called prothallus |
| (iv) Cycas | (iv) Dominant haploid leafy gametophyte alternating with partially dependent multicellular sporophyte |

Choose the correct answer from the options given below :

- (1) (a) - (ii), (b) - (iii), (c) - (iv), (d) - (i)
 (2) (a) - (iii), (b) - (iv), (c) - (i), (d) - (ii)
 (3) (a) - (ii), (b) - (iv), (c) - (i), (d) - (iii)
 (4) (a) - (iv), (b) - (i), (c) - (ii), (d) - (iii)

143. Which of the following occurs due to the presence of autosomal dominant trait ?

- (1) Myotonic dystrophy
 (2) Haemophilia
 (3) Thalassemia
 (4) Sickle cell anaemia

144. The anatomy of springwood shows some peculiar features. Identify the correct set of statements about springwood.

- (a) It is also called as the earlywood
 (b) In spring season cambium produces xylem elements with narrow vessels
 (c) It is lighter in colour
 (d) The springwood along with autumnwood shows alternate concentric rings forming annual rings
 (e) It has lower density

Choose the correct answer from the options given below:

- (1) (a), (c), (d) and (e) Only
 (2) (a), (b) and (d) Only
 (3) (c), (d) and (e) Only
 (4) (a), (b), (d) and (e) Only

145. Which part of the fruit, labelled in the given figure makes it a false fruit ?

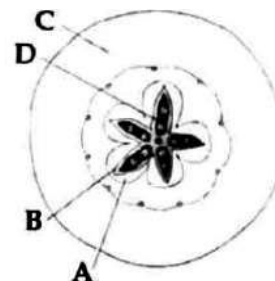

- (1) B → Endocarp
 (2) C → Thalamus
 (3) D → Seed
 (4) A → Mesocarp

146. In the following palindromic base sequences of DNA, which one can be cut easily by particular restriction enzyme ?

- (1) 5' GAATTC3' ; 3' CTTAAG5'
 (2) 5' CTCAGT3' ; 3' GAGTCA5'
 (3) 5' GTATTC3' ; 3' CATAAG5'
 (4) 5' GATACT3' ; 3' CTATGA5'

SECTION-A (Biology : Zoology)

147. While explaining interspecific interaction of population, (+) sign is assigned for beneficial interaction, (–) sign is assigned for detrimental interaction and (0) for neutral interaction. Which of the following interactions can be assigned (+) for another species involved in the interaction ?

- (1) Amensalism
- (2) Commensalism
- (3) Competition
- (4) Predation

148. Which one of the following will accelerate phosphorus cycle ?

- (1) Volcanic activity
- (2) Weathering of rocks
- (3) Rain fall and storms
- (4) Burning of fossil fuels

149. Given below are two statements : one is labelled as

Assertion (A) :

Mendel's law of Independent assortment does not hold good for the genes that are located closely on the same chromosome.

Reason (R) :

Closely located genes assort independently. In the light of the above statements, choose the correct answer from the options given below.

- (1) Both (A) and (R) are correct but (R) is not the correct explanation (A)
- (2) (A) is correct but (R) is not correct
- (3) (A) is not correct but (R) is correct
- (4) Both (A) and (R) are correct and (R) is the correct explanation of (A)

150. If a geneticist uses the blind approach for sequencing the whole genome of an organism, followed by assignment of function to different segments, the methodology adopted by him is called as :

- (1) Gene mapping
- (2) Expressed sequence tags
- (3) Bioinformatics
- (4) Sequence annotation

151. Given below are two statements

Statement I :

Autoimmune disorder is a condition where body defense mechanism recognizes its own cells as foreign bodies.

Statement II :

Rheumatoid arthritis is a condition where body does not attack self cells.

In the light of the above statements, choose the most appropriate answer from the options given below :

- (1) Both statement I and Statement II are incorrect
- (2) Statement I is correct but Statement II is incorrect
- (3) Statement I is incorrect but Statement II is correct
- (4) Both Statement I and Statement II are correct

152. Given below are two statements:

Statement I:

The coagulum is formed of network of threads called thrombins.

Statement II:

Spleen is the graveyard of erythrocytes.

In the light of the above statements, choose the most appropriate answer from the options given below :

- (1) Both Statement I and Statement II are incorrect
- (2) Statement I is correct but Statement II is incorrect
- (3) Statement I is incorrect but Statement II is correct
- (4) Both Statement I and Statement II are correct

153. Identify the asexual reproductive structure associated with penicillium :

- (1) Conidia
- (2) Gemmules
- (3) Buds
- (4) Zoospores

154. Given below are two statements:

Statement I :

The release of sperms into the seminiferous tubules is called spermiation.

Statement II :

Spermiogenesis is the process of formation of sperms spermatogonia.

In the light of the above statements, choose the most appropriate answer from the options given below :

- (1) Both Statement I and Statement II are incorrect
- (2) Statement I is correct but statement II is incorrect
- (3) Statement I is incorrect but Statement II is correct
- (4) Both Statement I and Statement II are correct

155. Under normal physiological conditions in human being every 100 ml of oxygenated blood can deliver _____ ml of O₂ to the tissues.
- (1) 5 ml
 - (2) 4 ml
 - (3) 10 ml
 - (4) 2 ml
156. In-situ conservation refers to :
- (1) Conserve only high risk species
 - (2) Conserve only endangered species
 - (3) Conserve only extinct species
 - (4) Protect and conserve the whole ecosystem
157. Natural selection where more individuals acquire specific character value other than the mean character value, leads to :
- (1) Dirrectional change
 - (2) Disruptive change
 - (3) Random change
 - (4) Stabilising change
158. Breeding crops with higher levels of vitamins and minerals or higher proteins and healthier fats is called :
- (1) Bio – remediation
 - (2) Bio – fortification
 - (3) Bio – accumulation
 - (4) Bio – magnification
159. Which of the following is present between the adjacent bones of the vertebral column ?
- (1) Cartilage
 - (2) Areolar tissue
 - (3) Smooth muscle
 - (4) Intercalated discs
160. Nitrogenous waste is excreted in the form of pellet or paste by :
- (1) Salamandra
 - (2) Hippocampus
 - (3) Pavo
 - (4) Ormithorhynchus
161. Which of the following statements with respect to Endoplasmic Reticulum is incorrect ?
- (1) SER is devoid of ribosomes
 - (2) In prokaryotes only RER are present
 - (3) SER are the sites for lipid synthesis
 - (4) RER has ribosomes attached to ER
162. Which of the following statements are true for spermatogenesis but do not hold true for Oogenesis :
- (a) It results in the formation of haploid gametes
 - (b) Differentiation of gamete occurs after the completion of meiosis
 - (c) Meiosis occurs continuously in a mitotically dividing stem cell population
 - (d) It is controlled by the Luteinising hormone (LH) and Follicle stimulating Hormone (FSH) secreted by the anterior pituitary
 - (e) It is initiated a puberty
- Choose the most appropriate answer from the options given below.
- (1) (b) and (c) only
 - (2) (b), (d) and (e) only
 - (3) (b), (c) and (e) only
 - (4) (c) and (e) only
163. Given below are two statements : one is labelled as Assertion (A) and the other is labelled as Reason (R).
- Assertion (A):**
All vertebrates are chordates but all chordates are not vertebrates.
- Reason (R) :**
Notochord is replaced by vertebral column in the adult vertebrates.
- In the light of the above statements, choose the most appropriate answer from the options given below :
- (1) Both (A) and (R) are correct but (R) is not the correct explanation of (A)
 - (2) (A) is correct but (R) is not correct
 - (3) (A) is not correct but (R) is correct
 - (4) Both (A) and (R) are correct and (R) is the correct explanation of (A)
164. In which of the following animals, digestive tract has additional chambers like crop and gizzard ?
- (1) Bufo, calaenoptera, Bangarus
 - (2) Catla, Columba, Crocodilus
 - (3) Pavo, Psittacula, Corvus
 - (4) Corous, Columba, Chameleon

165. Given below are two statements : one is labelled as Assertion (A) and the other is labelled as Reason (R).
- Assertion (A) :**
- Osteoporosis is characterised by decreased bone mass and increased chances of fractures.**
- Reason (R) :**
- Common cause of osteoporosis is increased levels of estrogen.**
- In the light of the above statements, choose the most appropriate answer from the options given below :**
- (1) Both (A) and (R) are correct but (R) is not the correct explanation (A)
 - (2) (A) is correct but (R) is not correct
 - (3) (A) is not correct but (R) is correct
 - (4) Both (A) and (R) are correct and (R) is the correct explanation of (A)
166. In gene therapy of Adenosine Deaminase (ADA) deficiency, the patient requires periodic infusion of genetically engineered lymphocytes because:
- (1) Gene isolated from marrow cells producing ADA is introduced into cells at embryonic stages
 - (2) Lymphocytes from patient's blood are grown in culture, outside the body.
 - (3) Genetically engineered lymphocytes are not immortal cells.
 - (4) Retroviral vector is introduced into these lymphocytes.
167. Select the incorrect statement with reference to mitosis :
- (1) Spindle fibres attach to centromere of chromosomes.
 - (2) Chromosomes decondense at telophase
 - (3) Splitting of centromere occurs at anaphase
 - (4) All the chromosomes lie at the equator at metaphase
168. In the taxonomic categories which hierarchical arrangement in ascending order is correct in case of animals :
- (1) Kingdom, Class, Phylum, Family, Order, Genus, Species
 - (2) Kingdom, Order, Class, Phylum, Family, Genus, Species
 - (3) Kingdom, Order, Phylum, Class, Family, Genus, Species
 - (4) Kingdom, Phylum, Class, Order, Family, Genus, Species
169. Given below are two statements :
- Statement I :**
- Restriction endonucleases recognise specific sequence to cut DNA known as palindromic nucleotide sequence**
- Statement II :**
- Restriction endonucleases cut the DNA strand a little away from the centre of the palindromic site.**
- In the light of the above statement, choose the most appropriate answer from the option given below :**
- (1) Both Statement I and Statement II are incorrect
 - (2) Statement I is correct but Statement II is incorrect
 - (3) Statement I is incorrect but Statement II is correct
 - (4) Both Statement I and Statement II are correct
170. Given below are two statements :
- Statement I :**
- Mycoplasma can pass through less than micron filter size.**
- Statement II :**
- Mycoplasma are bacteria with cell wall**
- In the light of the above statements, choose the most appropriate answer from the options given below :**
- (1) Both Statement I and Statement II are incorrect
 - (2) Statement I is correct but Statement II is correct
 - (3) Statement I is incorrect but Statement II is correct
 - (4) Both Statement I and Statement II are correct

- 171. Which of the following is not a connective tissue?**
- (1) Adipose tissue
 - (2) Cartilage
 - (3) Neuroglia
 - (4) Blood
- 172. Lippe's loop is a type contraceptive used as :**
- (1) Vaultbarrier
 - (2) Non- Medicated IUD
 - (3) Copper releasing IUD
 - (4) Cervical barrier
- 173. At which stage of life the oogenesis process is initiated :**
- (1) Embryonic development stage
 - (2) Birth
 - (3) Adult
 - (4) Puberty
- 174. Identify the microorganism which is responsible for the production of an immunosuppressive molecule cyclosporin A :**
- (1) Clostridium butylicum
 - (2) Aspergillus niger
 - (3) Streptococcus cerevisiae
 - (4) Trichoderma polysporum
- 175. Given below are two statements :**
- Statement I :**
Fatty acids and glycerols cannot be absorbed the blood.
- Statement II :**
Specialized lymphatic capillaries called lacteals carry chylomicrons into lymphatic vessel and ultimately into the blood.
- In the light of the above statements, choose the most appropriate answer from the options given below :**
- (1) Both Statement I and Statement II are incorrect
 - (2) Statement I is correct but Statement II is incorrect
 - (3) Statement I is incorrect but Statement II is correct
 - (4) Both Statement I and Statement II are correct
- 176. In a E-coli strain i gene mutated and its product can not bind the inducer molecule. If the growth medium is provided with lactose, what will be the outcome :**
- (1) z, y, a genes will be transcribed
 - (2) z,y,a genes will not be translated
 - (3) RNA polymerase will bind the promoter region
 - (4) Only z gene will get transcribed
- 177. Tegmina in cockroach, arises from :**
- (1) Mesothorax
 - (2) Metathorax
 - (3) Prothorax and Mesothorax
 - (4) Prothorax
- 178. Which of the following is not the function of conducting part of respiratory system:**
- (1) Inhaled air is humidified
 - (2) Temperature of inhaled air is brought to body temperature.
 - (3) Provides surface for diffusion of O₂ and CO₂
 - (4) It clears inhaled air from foreign particles
- 179. Which of the following, is a correct match for disease and its symptoms :**
- (1) Tetany - high Ca²⁺ level causing rapid spasms.
 - (2) Myasthenia gravis - Genetic disorder resulting in weakening and paralysis of skeletal muscle.
 - (3) Muscular dystrophy - An auto immune disorder causing progressive degeneration of skeletal muscle.
 - (4) Arthritis - Inflamed joints
- 180. Regarding Meiosis, which of the statements is incorrect :**
- (1) DNA replication occurs in S phase of Meiosis-II
 - (2) Pairing of homologous chromosomes and recombination occurs in Meiosis-I
 - (3) Four haploid cells are formed at the end of Meiosis-II.
 - (4) There are two stages in Meiosis, Meiosis-I and II.
- 181. Detritivores breakdown detritus into smaller particles. This process is called :**
- (1) Fragmentation
 - (2) Humification
 - (3) Decomposition
 - (4) Catabolism
- 182. If the length of a DNA molecule is 1.1 metres, what will be the approximate number of base pairs :**
- (1) 6.6×10⁹bp
 - (2) 3.3×10⁶bp
 - (3) 6.6×10⁶bp
 - (4) 3.3×10⁹bp

- 183. Which of the following functions is not performed by secretions from salivary glands:**
- (1) Digestion of complex carbohydrates
 - (2) Lubrication of oral cavity
 - (3) Digestion of disaccharides
 - (4) Control bacterial population in mouth
- 184. A dehydration reaction links two glucose molecules to produce maltose. If the formula for glucose is $C_6H_{12}O_6$ then what is the formula for maltose:**
- (1) $C_{12}H_{24}O_{12}$
 - (2) $C_{12}H_{22}O_{11}$
 - (3) $C_{12}H_{24}O_{11}$
 - (4) $C_{12}H_{20}O_{10}$
- 185. If '8' Drosophila in a laboratory population of '80' died during a week, the death rate in the population is _____ individuals per Drosophila per week:**
- (1) 10
 - (2) 1.0
 - (3) zero
 - (4) 0.1
- Section - B (Biology: Zoology)**
-
- 186. Given below are two statements :**
- Statement I :**
- In a scrubber the exhaust from the thermal plant is passed through the electric wires to charge the dust particles
- Statement II :**
- Particulate matter (PN 2.5) can not be removed by scrubber but can be removed by an electrostatic precipitator
- In the light of the above statements, choose the most appropriate answer from the options given below
- (1) Both statement I and statement II are incorrect
 - (2) Statement I is correct but statement II is incorrect
 - (3) Statement I is incorrect but statement II is correct
 - (4) Both statement I and statement II are correct
- 187. Which of the following is a correct statement ?**
- (1) Bacteria are exclusively heterotrophic organisms
 - (2) Slime moulds are saprophytic organisms classified under Kingdom Monera
 - (3) Mycoplasma have DNA, Ribosome and cell wall
 - (4) Cyanobacteria are a group of autotrophic organisms classified under Kingdom Monera
- 188. Ten E.coli cells with ^{15}N -dsDNA are incubated in medium containing ^{14}N nucleotide. After 60 minutes, how many E.coli cells with have DNA totally free from ^{15}N ?**
- (1) 40 cells
 - (2) 60 cells
 - (3) 80 cells
 - (4) 20 cells
- 189. Select the incorrect statement with respect to acquired immunity**
- (1) Anamnestic response is elicited on subsequent encounters with the same pathogen
 - (2) Anamnestic response is due to memory of first encounter
 - (3) Acquired immunity is non-specific type of defence present at the time of birth
 - (4) Primary response is produced when our body encounters a pathogen for the first time
- 190. Statements related to human Insulin are given below. Which statement (s) is/are correct about genetically engineered Insulin ?**
- (a) Pro-hormone insulin contain extra stretch of C-peptide
 - (b) A-p-eptide and B-peptide chains of insulin were produced separately in E.coli, extracted and combined by creating disulphide bond between them
 - (c) Insulin used for treating Diabetes was extracted from Cattles and Pigs
 - (d) Pro-hormone Insulin needs to be processed for converting into a mature and functional hormone
 - (e) Some patients develop allergic reactions to the foreign insulin
- Choose the most appropriate answer from the options given below
- (1) (b) only
 - (2) (c) and (d) only
 - (3) (c), (d) and (e) only
 - (4) (a), (b) and (d) only

191. Which of the following are not the effects of Parathyroid hormone ?

- (a) Stimulates the process of bone resorption
- (b) Decreases Ca^{2+} level in bond
- (c) Reabsorption of Ca^{2+} level in blood
- (d) Decreases the absorption of Ca^{2+} from digested food
- (e) Increases metabolism of carbohydrates

Choose the most appropriate answer from the options given below

- (1) (b), (d) and (e) only
- (2) (a) and (e) only
- (3) (b) and (c) only
- (4) (a) and (c) only

192. Select the incorrect statement regarding synapses:

- (1) Electrical current can flow directly from one neuron into the other across the electrical synapse
- (2) Chemical synapses use neurotransmitters
- (3) Impulse transmission across a chemical synapse is always faster than that across an electrical synapse
- (4) The membranes of presynaptic and postsynaptic neurons are in close proximity in an electrical synapse

193. Match List - I with List - II

List - I	List - II
(a) Bronchiles	(i) Dense Regular connective tissue
(b) Goblet cell	(ii) Loose Connective tissue
(c) Tendons	(iii) Glandular Tissue
(d) Adipose tissue	(iv) Ciliated Epithelium

Choose the correct answer from the options given below

- (1) (a)-(i), (b)-(ii), (c)-(iii), (d) - (iv)
- (2) (a)-(ii), (b)-(i), (c)-(iv), (d) - (iii)
- (3) (a)-(iii), (b)-(iv), (c)-(ii), (d) - (ii)
- (4) (a)-(iv), (b)-(iii), (c)-(i), (d) - (ii)

194. The recombination frequency between the genes a & c is 5%, b & c is 15%, b & d is 9%, a & b is 20%, c & d is 24% and a & d is 29%. What will be the sequence of these genes on a linear chromosomes?

- (1) d, b, a, c
- (2) a, b, c, d
- (3) a, c, b, d
- (4) a, d, b, c

195. If a colour blind female marries a man whose mother was also colour blind, what are the chances of her progeny having colour blindness?

- (1) 50%
- (2) 75%
- (3) 100%
- (4) 25%

196. Match List - I with List - II

List - I (Biological Molecules)	List - II (Biological functions)
(a) Glycogen	(i) Hormone
(b) Globulin	(ii) Biocatalyst
(c) Steroids	(iii) Antibody
(d) Thrombin	(iv) Storage product

Choose the correct answer from the option given below:

- (1) (a)-(iv), (b)-(ii), (c)- (i), (d)-(iii)
- (2) (a)-(ii), (b)-(iv), (c)- (iii), (d)-(i)
- (3) (a)-(iv), (b)-(iii), (c)- (i), (d)-(ii)
- (4) (a)-(iii), (b)-(ii), (c)- (iv), (d)-(i)

197. Which of the following is not a desirable features of a cloning vector ?

- (1) Presence of a marker gene
- (2) Presence of single restriction enzyme site
- (3) Presence of two or more recognition sites
- (4) Presence of origin of replication

198. Which of the following statements is not true ?

- (1) Sweet potato and potato is an example of analogy
- (2) Homology indicates common ancestry
- (3) Flippers of penguins and dolphins are a pair of homologous organs
- (4) Analogous structures are a result of convergent evolution

199. Which one of the following statements is correct?

- (1) The tricuspid and the bicuspid valves open due to the pressure exerted by the simultaneous contraction of the atria
- (2) Blood moves freely from atrium to the ventricle during joint diastole
- (3) Increased ventricular pressure causes closing of the semilunar valves
- (4) The atrio - ventricular node (AVN) generates and action potential to stimulate atrial contraction

200. Match List - I with List - II with respect to methods of Contraception and their respective actions :

List - I	List - II
(a) Diaphragms	(i) Inhibit ovulation and implantation
(b) Contraceptive Pills	(ii) Increase phagocytosis of sperm within uterus
(c) Intra Uterine Devices	(iii) Absence of Menstrual cycle and ovulation following parturition
(d) Lactational Amenorrhoea	(iv) They cover the cervix blocking the entry of sperms

Choose the correct answer from the options given below

- (1) (a)-(iv), (b)-(i), (c)- (ii), (d)-(iii)
- (2) (a)-(ii), (b)-(iv), (c)- (i), (d)-(iii)
- (3) (a)-(iii), (b)-(ii), (c)- (i), (d)-(iv)
- (4) (a)-(iv), (b)-(i), (c)- (iii), (d)-(ii)