

1

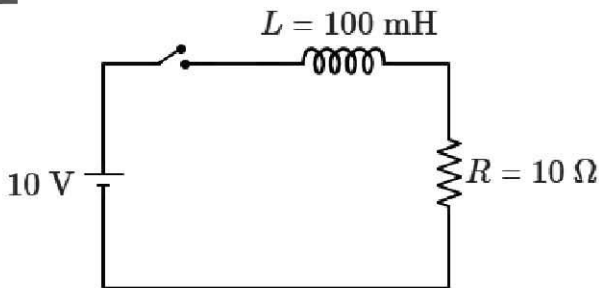

An ideal inductor-resistor-battery circuit is switched on at  $t = 0$  s. At time  $t$ , the current is  $i = i_0 \left(1 - e^{\left(-\frac{t}{\tau}\right)}\right)$  A, where  $i_0$  is the steady-state value. The time at which the current becomes  $0.5i_0$  is: [Given  $\ln(2) = 0.693$ ]

1.  $6.93 \times 10^3$  s
2. 6.93 ms
3. 69.3 s
4. 6.93 s

2

The percentage errors in the measurement of mass and momentum of an object are 1% and 2% respectively. The percentage error in the measurement of kinetic energy of the object is:

1. 1%
2. 3%
3. 4%
4. 5%

3

Two identical rectangular plane sheet  $A$  and  $B$  each of surface charge density  $\epsilon_0 \text{Cm}^{-2}$  are placed parallel to each other as shown in figure. The electric field at the mid point  $P$  will be:

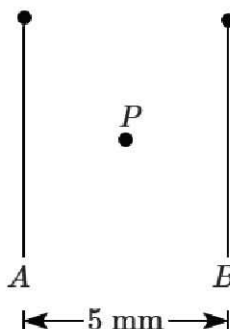

1.  $2 \text{ NC}^{-1}$
2.  $1 \text{ NC}^{-1}$
3.  $0.5 \text{ NC}^{-1}$
4. zero

4 Match List-I with List-II:

	List-I (Application of Gauss Law)		List-II (Value of $ E $ )
A	Field inside thin shell	I	$\frac{\lambda}{2\pi\epsilon_0 r} \hat{r}$
B	Field outside thin shell	II	$\frac{q}{4\pi\epsilon_0 R^2} \hat{r}$
C	Field of thin shell at the surface	III	$\frac{q}{4\pi\epsilon_0 r^2} \hat{r}$
D	Field due to long charged wire	IV	zero

(Here symbols have their usual meaning and  $R$  is the radius of the thin shell)

Choose the correct answer from the options given below:

1. A-IV, B-III, C-I, D-II
2. A-I, B-II, C-III, D-IV
3. A-IV, B-III, C-II, D-I
4. A-I, B-III, C-II, D-IV

5

In Young's double slit experiment, if the wavelength of light used is increased (say from violet to red) then the:

1.	fringe width decreases.
2.	fringe width increases.
3.	central bright fringe becomes dark.
4.	fringe width remains unaltered.

6

The value of  $R$  in the given circuit when there is no current in the  $5\Omega$  resistor is:

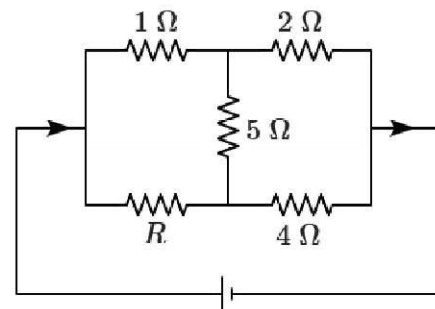

1.  $12 \Omega$
2.  $9 \Omega$
3.  $3 \Omega$
4.  $2 \Omega$

**7** A wire of length  $L$  and radius  $r$  ( $r \ll L$ ) is kept floating on the surface of a liquid of density  $\rho$ . The maximum radius of the wire for which it may not sink is (Surface tension of liquid is  $T$ ):

1.  $\sqrt{\frac{T}{\rho g}}$
2.  $\sqrt{\frac{2T}{\rho g}}$
3.  $\sqrt{\frac{2T\rho}{\pi g}}$
4.  $\sqrt{\frac{2T}{\pi\rho g}}$

**8** Match List-I with List-II (The symbols carry their usual meaning)

List I		List II
A $\oint \vec{E} \cdot d\vec{A} = \frac{Q}{\epsilon_0}$	I	Ampere-Maxwell's Law
B $\oint \vec{B} \cdot d\vec{A} = 0$	II	Faraday's Law
C $\oint \vec{E} \cdot d\vec{l} = \frac{-d(\phi)}{dt}$	III	Gauss Law of electrostatics
D $\oint \vec{B} \cdot d\vec{l} = \mu_0 i_c + \mu_0 \epsilon_0 \frac{d(\phi_E)}{dt}$	IV	Gauss law of magnetism

Choose the correct answer from the options given below:

1. A-III, B-IV, C-II, D-I
2. A-IV, B-III, C-II, D-I
3. A-III, B-II, C-IV, D-I
4. A-IV, B-I, C-III, D-II

**9** Match List I with List II

List-I (Measured values)		List-II (Significant figures)
A 0.001213	I	2
B $2.1 \times 10^{16}$	II	3
C 3.70	III	1
D 3000	IV	4

Choose the correct answer from the options given below:

1. A-III, B-II, C-I, D-IV
2. A-III, B-I, C-II, D-IV
3. A-I, B-II, C-IV, D-III
4. A-IV, B-I, C-II, D-III

**10** Match List-I with List-II

List-I (Series)		List-II (Wave number in $\text{cm}^{-1}$ )
A. Balmer series	I.	$R \left( \frac{1}{1^2} - \frac{1}{n^2} \right)$
B. Lyman series	II.	$R \left( \frac{1}{4^2} - \frac{1}{n^2} \right)$
C. Brackett series	III.	$R \left( \frac{1}{5^2} - \frac{1}{n^2} \right)$
D. Pfund series	IV.	$R \left( \frac{1}{2^2} - \frac{1}{n^2} \right)$

Choose the correct answer from the options given below

1. A-I, B-IV, C-III, D-II
2. A-II, B-III, C-IV, D-I
3. A-IV, B-I, C-II, D-III
4. A-III, B-II, C-I, D-IV

**11** A conducting circular loop of face area  $2.5 \times 10^{-3} \text{ m}^2$  is placed perpendicular to a magnetic field which varies as  $B = 0.5 \sin(100\pi t)$  T. The magnitude of induced emf at time  $t = 0$  s is:

1.  $0.125\pi$  mV
2.  $125\pi$  mV
3.  $125\pi$  V
4.  $12.5\pi$  mV

**12** The pressure experienced by a swimmer 20 m below the water surface in a lake is appropriately [Given density of water =  $10^3 \text{ kg m}^{-3}$ ,  $g = 10 \text{ ms}^{-2}$  and  $1 \text{ atm} = 10^5 \text{ Pa}$ ]:

1. 1 atm
2. 2 atm
3. 3 atm
4. 4 atm

**13** A vernier calipers has 1 mm marks on the main scale. It has 20 equal divisions on the vernier scale which match with 16 main scale divisions. The least count of this vernier calipers is:

1. 0.02 mm
2. 0.05 mm
3. 0.10 mm
4. 0.20 mm

**14** An object falls freely from height  $h$  above the ground. It travels  $\frac{5}{9}h$  in the last 1 s. Then height  $h$  is:  
(Given  $g = 10 \text{ ms}^{-2}$ )

1. 5 m
2. 25 m
3. 45 m
4. 58 m

**15** Consider a thin circular ring (A), a circular disc (B), a hollow Cylinder (C) and a solid cylinder (D) of the same radius  $R$  and of same mass:

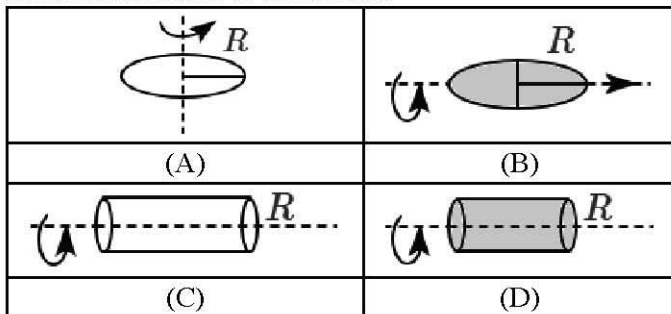

If  $I_A, I_B, I_C$  and  $I_D$  are their moments of inertia about the axis shown, then:

Choose the correct answer from the options given below:

1.  $I_A = I_C$  and  $2I_B = I_D$
2.  $I_A = 2I_B$  and  $2I_C = I_D$
3.  $2I_A = I_C$  and  $I_B = 2I_D$
4.  $I_A = I_B = I_C = 2I_D$

**16** Zener diode works:

1.	in forward bias only.
2.	in reverse bias only.
3.	as a voltage regulator in forward bias and as a simple pn junction diode in reverse bias.
4.	as a voltage regulator in reverse bias and as a simple pn junction diode in forward bias.

**17** Match List-I with List-II

	List-I (Material)		List-II (Example)
A	Diamagnet	I	Alnico
B	Paramagnet	II	Copper
C	Soft ferromagnet	III	Aluminium
D	Hard ferromagnet	IV	Gadolinium

Choose the correct answer from the options given below:

1. A-I, B-II, C-III, D-IV
2. A-IV, B-III, C-II, D-I
3. A-III, B-II, C-I, D-IV
4. A-II, B-III, C-IV, D-I

**18** For an adiabatic process, the factor which remains constant is [All the notations have their usual meaning]:

1.  $P^{\gamma-1} T^{\gamma}$
2.  $TV^{1-\gamma}$
3.  $V^{\gamma-1} T^{\gamma}$
4.  $P^{1-\gamma} T^{\gamma}$

**19** An excited heavy nucleus  ${}^A_Z X$  emits radiations in the following sequence:

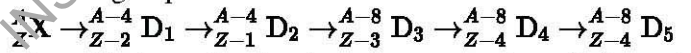

where  $Z, A$  are the atomic and mass number of element  $X$ , respectively. The possible emitted particles or radiations in the sequence, respectively are:

1.  $e^+, \alpha, e^-, \alpha, \gamma$
2.  $e^-, \alpha, e^+, \alpha, \gamma$
3.  $\alpha, e^-, \alpha, e^+, \gamma$
4.  $\alpha, e^+, \alpha, e^-, \gamma$

**20** Time taken by sunlight to pass through a glass slab of thickness 5 mm and refractive index 1.5 is:

1.  $\left(\frac{5}{3}\right) \times 10^{-8} \text{ s}$
2.  $\left(\frac{5}{2}\right) \times 10^{-11} \text{ s}$
3.  $\left(\frac{5}{3}\right) \times 10^{-11} \text{ s}$
4.  $\left(\frac{5}{2}\right) \times 10^{-8} \text{ s}$

**21** A particle is displaced through  $(3\hat{i} + 4\hat{j})$  m by force  $2\hat{i}$  N. The work done is:

1. 14 J
2. 8 J
3. 6 J
4. 10 J

**22** A body of mass 6 kg is moving from its initial position **A** to the next position **B** as shown in figure. From **A** to **B**, the value of momentum of the body is: (in SI unit)

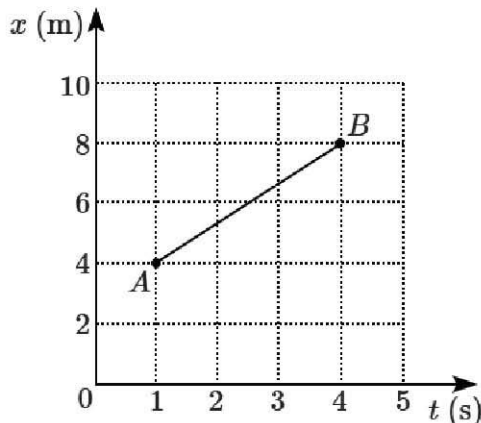

1. 24
2. 12
3. 8
4. 6

**23** The best suited curve showing the variations of susceptibility ( $\chi$ ) of a paramagnetic material in free space with temperature ( $T$ ) is:

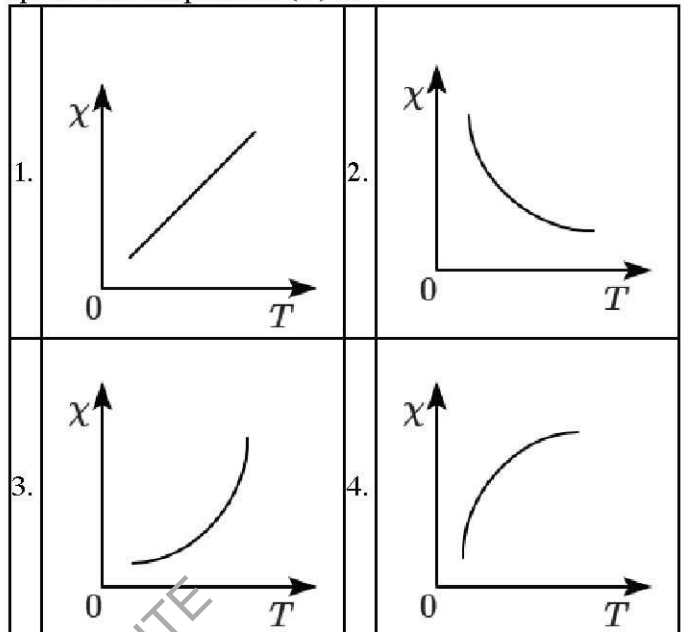

**24** A body weighing 100 N on the surface of earth weights  $x$  kg- $\text{ms}^{-2}$  at a height  $\frac{1}{9}R_E$  above the surface of earth.

The value of  $x$  ( $g = 10 \text{ ms}^{-2}$  at surface of earth and  $R_E$  is the radius of earth):

1. 72
2. 54
3. 81
4. 62

**25** The speed ( $s$ ) of a car as a function of time ( $t$ ) is shown figure, The distance travelled by the car in 8 seconds is:

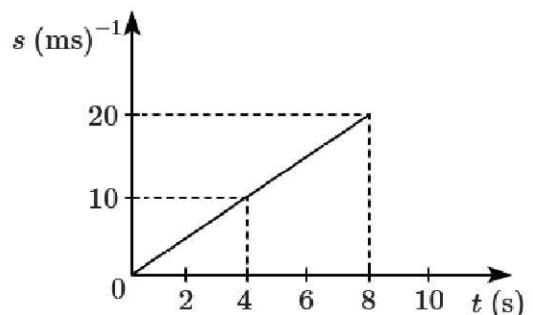

1. 180 m
2. 60 m
3. 80 m
4. 18 m

- 26** The equivalent resistance  $R_{AB}$  between points  $A$  and  $B$  in the given network is:

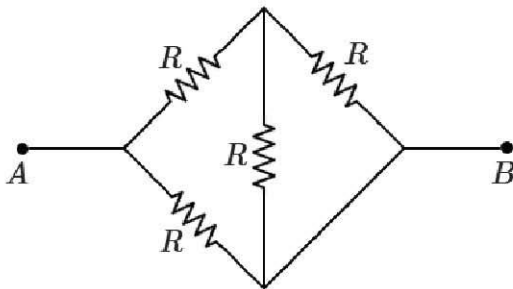

1.  $1R$
2.  $\frac{3}{5}R$
3.  $\frac{7}{8}R$
4.  $\frac{5}{8}R$

- 27**  $L, C$  and  $R$  represent the value of inductance, capacitance and resistance, respectively. The factor which has the same dimensions as that of the inverse of resonance frequency is:

1.  $\sqrt{LC}$
2.  $\sqrt{\frac{L}{C}}$
3.  $\frac{C}{L}$
4.  $\frac{R}{L}$

- 28** If  $F = \alpha t^2 - \beta t$  is the magnitude of the force acting on a particle at an instant  $t$  then the time, at which the force becomes constant, is (where  $\alpha$  and  $\beta$  are constants):

1.  $\frac{\beta}{\alpha}$
2.  $\frac{2\alpha}{\beta}$
3.  $\frac{2\beta}{\alpha}$
4. zero

- 29** If  $\vec{E}$  and  $\vec{B}$  represent the electric field vector and magnetic field vector, respectively, in an electromagnetic wave then the direction of EM wave is along:

1.  $\vec{E}$
2.  $\vec{B}$
3.  $\vec{E} \times \vec{B}$
4.  $\vec{B} \times \vec{E}$

- 30** Radiation of wavelength  $280 \text{ nm}$  is used in an experiment of photoelectric effect with cathode of work function,  $2.5 \text{ eV}$ . The maximum kinetic energy of the photoelectrons is [Take  $h = 6.62 \times 10^{-34} \text{ J s}$  and  $c = 3 \times 10^8 \text{ ms}^{-1}$ ]:

1.  $4.4 \text{ eV}$
2.  $7.103 \times 10^{-15} \text{ J}$
3.  $1.9 \text{ eV}$
4.  $4.60 \text{ eV}$

- 31** If  $i$  is the angle of incidence and  $i'$  is the angle of emergence on a prism, then the relation between  $i$  and  $i'$  to obtain an angle of minimum deviation is:

1.  $i = i'$
2.  $i > i'$
3.  $i < i'$
4.  $i = 0$

- 32** Given below are two statements: One is labelled as Assertion A and the other is labelled as Reason R.

<b>Assertion A:</b>	A glass tube partially filled with water represents an open organ pipe.
<b>Reason R:</b>	The open end corresponds to an antinode and the end in contact with water, to a node.

In the light of the above statements, choose the correct answer from the options given below:

1.	Both A and R are true and R is the correct explanation of A.
2.	Both A and R are true and R is NOT the correct explanation of A.
3.	A is true but R is false.
4.	A is false but R is true.

- 33** Given below are two statements:

<b>Statement I:</b>	The de Broglie wavelength associated with a material particle depends on its charge and nature.
<b>Statement II:</b>	The wave nature of particles in sub-atomic domain is significant and measurable.

In the light of the above statements, choose the most appropriate answer from the options given below:

1.	Both Statement I and Statement II are correct.
2.	Both Statement I and Statement II are incorrect.
3.	Statement I is correct but Statement II is incorrect.
4.	Statement I is incorrect but Statement II is correct.

**34** A solar cell is a:

1. forward biased zener diode.
2. type of light-emitting diode.
3. diode working on the principle of photo-voltaic effect.
4. type of photo-diode with external biasing.

**35** The graph which shows the correct variation of  $\frac{1}{v}$  with  $\frac{1}{u}$  for a concave mirror, where  $u$  is the object distance and  $v$  is the image distance, is:

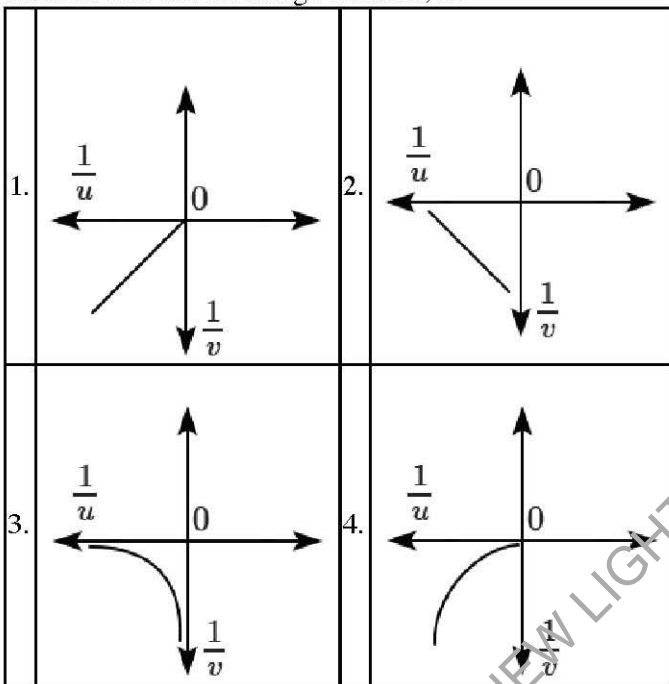

**36** The correct input ( $A, B$ ) - output ( $Y$ ) combination for the given circuit is:

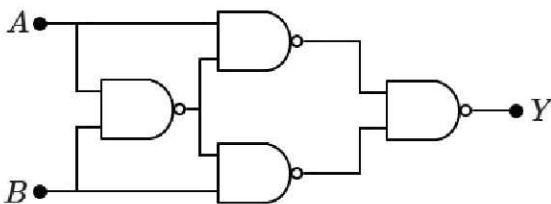

1.  $A = 1, B = 1, Y = 1$
2.  $A = 0, B = 1, Y = 1$
3.  $A = 1, B = 0, Y = 0$
4.  $A = 0, B = 0, Y = 1$

**37** A rocket is fired vertically upward with a speed of  $\frac{v_e}{\sqrt{2}}$  from the earth's surface, where  $v_e$  is escape velocity on the surface of earth. The distance from the surface of earth upto which the rocket can go before returning to the earth is (Given radius of earth = 6400 km):

1. 1600 km
2. 3200 km
3. 6400 km
4. 12800 km

**38** An ideal gas at  $0^\circ\text{C}$  and atmospheric pressure  $P$  has volume  $V$ . The percentage increase in its temperature needed to expand it to  $3V$  at constant pressure is:

1. 100%
2. 200%
3. 300%
4. 50%

**39** A particle of mass  $m$  and charge  $q$  is placed in a uniform electric field  $E$  at  $t = 0$  s. The kinetic energy of the particle after time  $t$  is:

1.  $\frac{Eqm}{t}$
2.  $\frac{E^2 q^2 t^2}{2m}$
3.  $\frac{2m}{Eq^2 t^2}$
4.  $\frac{Eq^2 m}{2t^2}$

**40** There are two heaters  $A$  and  $B$ . Heater  $A$  takes time  $t_1$  to boil a given quantity of water, while  $B$  takes time  $t_2$  to boil the same quantity of water across same supply voltage. If the two heaters are connected in series, time taken by this combination to boil the same quantity of water will be:

1.  $\frac{t_1 t_2}{t_1 + t_2}$
2.  $t_1 + t_2$
3.  $\frac{1}{2}(t_1 + t_2)$
4.  $\frac{t_1 t_2}{2(t_1 + t_2)}$

**41** If  $T_1, T_2, T_3, T_4$  and  $T_5$  represent the tension in the string of a simple pendulum when the bob is at the left extreme, right extreme, mean, any intermediate left and any intermediate right positions, respectively. Then which of the following relations are correct?

- $T_1 = T_2$
- $T_3 > T_2$
- $T_4 > T_3$
- $T_3 = T_4$
- $T_5 > T_2$

Choose the most appropriate answer from the options given below:

- A, B and C only
- B, C and D only
- A, B and E only
- C, D and E only

**42** Arrange the following in the order of their resistance.

A.	(0 to 1 A) ranged ammeter.
B.	(0 to 100 mA) ranged milli-ammeter.
C.	(0 to 500 $\mu$ A) ranged micro-ammeter.
D.	(0 to 100 V) ranged voltmeter.

Choose the correct answer from the options given below:

- $A > B > C > D$
- $D > C > B > A$
- $D > A > B > C$
- $C > B > A > D$

**43** Object **A** has half the kinetic energy as that of object **B**. The object **B** has half the mass as that of the object **A**. The object **A** speeds up by  $1 \text{ ms}^{-1}$  and then has the same kinetic energy as that of object **B**. The initial speed of object of object **A** is nearly (Take  $\sqrt{2} \cong 1.4$ ):

- $0.5 \text{ ms}^{-1}$
- $1 \text{ ms}^{-1}$
- $2.5 \text{ ms}^{-1}$
- $4.8 \text{ ms}^{-1}$

**44** The length of a magnetized iron bar is  $L$  and its magnetic moment is  $M$ . When this bar is bent to form a semicircle its magnetic moment is:

- $M$
- $\frac{M\pi}{2}$
- $\frac{M}{2\pi}$
- $\frac{2M}{\pi}$

**45** A rod of length  $L$  rotates with a small uniform angular velocity  $\omega$  about its perpendicular bisector. A uniform magnetic field  $B$  exists parallel to the axis of rotation. The potential difference between the centre of the rod and an end is:

- $\frac{B\omega L^2}{8}$
- $\frac{B\omega L^2}{2}$
- $\frac{B\omega L^2}{4}$
- zero

**46** The ratio of nuclear densities and nuclear volumes of  ${}^{56}_{26}\text{Fe}$  and  ${}^4_2\text{He}$  are, respectively:

- 13 : 1 and 14 : 1
- 14 : 1 and 1 : 1
- 1 : 1 and 14 : 1
- 1 : 1 and 13 : 1

**47** For a smoothly running analog clock, the ratio of number of rotations made in a day by the hour hand and second hand respectively, is:

- 24 : 1
- 1 : 720
- 1 : 60
- 2 : 5

**48** If an unpolarised light is incident on a plane surface of refractive index  $\sqrt{3}$  at Brewster's angle then the angle of refractive is:

- $0^\circ$
- $30^\circ$
- $60^\circ$
- $90^\circ$

**49** A body is falling freely in a resistive medium. The motion of the body is described by  $\frac{dv}{dt} = 4 - 2v$ , where  $v$  is the velocity of body at any instant (in  $\text{ms}^{-1}$ ). The initial acceleration and terminal velocity of the body, respectively, are:

- $4 \text{ ms}^{-2}, 2 \text{ ms}^{-1}$
- $2 \text{ ms}^{-2}, 4 \text{ ms}^{-1}$
- $6 \text{ ms}^{-2}, 2 \text{ ms}^{-1}$
- $2 \text{ ms}^{-2}, 6 \text{ ms}^{-1}$

**50** A dielectric slab of dielectric constant **3** having the same area of cross-section as that of parallel plate capacitor but of thickness  $\frac{3}{4}$  of the separation of the plates is inserted into the capacitor. The ratio of potential difference across the plates without dielectric to that with dielectric is:

1. **1 : 2**
2. **2 : 3**
3. **3 : 2**
4. **2 : 1**

**51** Given below are two statements:

<b>Statement I:</b>	Benzoic acid produces effervescence on treatment with aq. <b>NaHCO<sub>3</sub></b>
<b>Statement II:</b>	The effervescence is due to the release of hydrogen gas.

In the light of the above statements, choose the not appropriate answer from the options give below:

1. Both **Statement I** and **Statement II** are correct.
2. Both **Statement I** and **Statement II** are incorrect.
3. **Statement I** is correct but **Statement II** is incorrect.
4. **Statement I** is incorrect but **Statement II** is correct.

**52**

The standard enthalpy of neutralization is **-57.3 KJ mol<sup>-1</sup>** as:

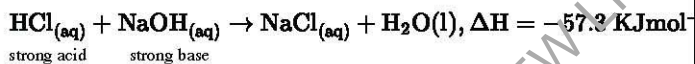

The enthalpy of neutralization of **0.25 mol** of HCl by **0.25 mol** of **NaOH** is :

1. **-57.3 kJ mol<sup>-1</sup>**
2. **-28.3 kJ mol<sup>-1</sup>**
3. **-14.32 kJ mol<sup>-1</sup>**
4. **+57.3 kJ mol<sup>-1</sup>**

**53** Which one of the following molecules is paramagnetic?

1. **H<sub>2</sub>**
2. **Li<sub>2</sub>**
3. **C<sub>2</sub>**
4. **O<sub>2</sub>**

**54** Consider the reaction in equilibrium



at **500 K**. The concentration of **PCl<sub>5</sub> = 1.40 M**, concentration of **Cl<sub>2</sub> = 1.60 M**, concentration of **PCl<sub>3</sub> = 1.60M**. Calculate **K<sub>c</sub>**

1. **2.00**
2. **2.6**
3. **1.83**
4. **3.4**

**55** Phenanthrene is an aromatic compound and follows Huckel's **(4n + 2)π** electron rule. The value of **n** is:

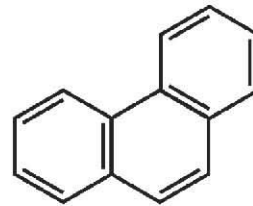

1. **0**
2. **1**
3. **2**
4. **3**

**56** Arrange the following hydrides in the order of decreasing bond angle:

- A. **SbH<sub>3</sub>**
- B. **AsH<sub>3</sub>**
- C. **PH<sub>3</sub>**
- D. **NH<sub>3</sub>**

Choose the correct answer from the options given below:

1. **B > A > D > C**
2. **B > A > C > D**
3. **D > C > B > A**
4. **A > C > B > D**



**57** 4.74 g of an inorganic compound contains 0.39g of K, 0.27 g Al, 1.92 g of  $\text{SO}_4$  radicals and 2.16 g of water. If molar mass of the compound is  $948 \text{ g mol}^{-1}$ , the molecular formula of the inorganic compound is:

1.  $\text{KAl}(\text{SO}_4)_2 \cdot 12\text{H}_2\text{O}$
2.  $\text{K}_2\text{Al}_2(\text{SO}_4)_6 \cdot 12\text{H}_2\text{O}$
3.  $\text{K}_2\text{SO}_4 \cdot \text{Al}_2(\text{SO}_4)_3 \cdot 24\text{H}_2\text{O}$
4.  $\text{K}_2\text{SO}_6 \cdot \text{Al}_2(\text{SO}_4)_3 \cdot 12\text{H}_2\text{O}$

**58** The method used for quantitative estimation of halogens is:

1. Dumas method
2. Carius method
3. Kjeldahl's method
4. Combustion method

**59** Molar mass of a compound (X) whose 2.6 mol weighs 312 g is:

1.  $312 \text{ g mol}^{-1}$
2.  $120 \text{ g mol}^{-1}$
3.  $60 \text{ g mol}^{-1}$
4.  $811.2 \text{ g mol}^{-1}$

**60** Identify the incorrect statement:

1.	The oxidation state and coordination number (or covalency) of Al in $[\text{AlCl}(\text{H}_2\text{O})_5]^{2+}$ are +3 and 6, respectively.
2.	$\text{Na}_2\text{O}$ is a basic oxide and $\text{Cl}_2\text{O}_7$ is an acidic oxide
3.	The following four species are called isoelectronic species: $\text{O}^{2-}$ , $\text{F}^-$ , $\text{Na}^+$ and $\text{Mg}^{2+}$
4.	Among the four species Mg, Al, $\text{Mg}^{2+}$ and $\text{Al}^{3+}$ , the smallest one is Al.

**61** Which of the following reaction is not a disproportionation reaction?

1.  $2\text{F}_2(\text{g}) + 2\text{OH}^-(\text{aq}) \rightarrow 2\text{F}^-(\text{aq}) + \text{OF}_2(\text{g}) + \text{H}_2\text{O}(\text{l})$
2.  $\text{Cl}_2(\text{g}) + 2\text{OH}^-(\text{aq}) \rightarrow \text{ClO}^-(\text{aq}) + \text{Cl}^-(\text{aq}) + \text{H}_2\text{O}(\text{l})$
3.  $2\text{NO}_2(\text{g}) + 2\text{OH}^-(\text{aq}) \rightarrow \text{NO}_2^-(\text{aq}) + \text{NO}_3^-(\text{aq}) + \text{H}_2\text{O}(\text{l})$
4.  $2\text{H}_2\text{O}_2(\text{aq}) \rightarrow 2\text{H}_2\text{O}(\text{l}) + \text{O}_2(\text{g})$

**62** Isotope of an element contains 19.23% more neutrons as compared to protons. The correct element along with its mass number is:

(Given Atomic number Fe : 26, Co : 27 )

1.  $^{56}\text{Fe}$
2.  $^{57}\text{Fe}$
3.  $^{57}\text{Co}$
4.  $^{60}\text{Co}$

**63** Which of the following expression is correct for the reaction given below?



1.	$\frac{-\Delta[\text{H}]}{\Delta t} = \frac{2\Delta[\text{H}_2]}{\Delta t}$	2.	$\frac{-\Delta[\text{HI}]}{\Delta t} = \frac{4\Delta[\text{I}_2]}{\Delta t}$
3.	$\frac{-\Delta[\text{HI}]}{\Delta t} = \frac{4\Delta[\text{H}_2]}{\Delta t}$	4.	$\frac{-\Delta[\text{H}]}{\Delta t} = \frac{\Delta[\text{H}_2]}{\Delta t}$

64 Given below are two statement:

<b>Statement I:</b>	The energy of the $\text{He}^+$ ion in $n = 2$ state is same as the energy of H atom in $n = 1$ state
<b>Statement II:</b>	It is possible to determine simultaneously the exact position and exact momentum of an electron in H atom.

In the light of the above Statements,, choose the correct answer from the options given below:

- Both Statement I and Statement II are true
- Both Statement I and Statement II are false
- Statement I is true but Statement II is false
- Statement I is false but Statement II is true

65

Match List -I with List -II:

	List-I (Reactions)		List-II (Products)
A.	$\text{CH}_3\text{CH}=\text{CH}_2 + \text{H}_2\text{O} + \text{O} \xrightarrow[273\text{ K}]{\text{dil. KMnO}_4}$	I.	$(\text{CH}_3)_2\text{C} = \text{O} + \text{CO}_2 + \text{H}_2\text{O}$
B.	$\text{CH}_3\text{CH}=\text{CH}_2 \xrightarrow[\text{(ii) Zn + H}_2\text{O}]{\text{(i) O}_3}$	II.	$\text{CH}_3\text{CH}(\text{OH})\text{CH}_2\text{OH}$
C.	$\text{H}_3\text{C} \diagdown \text{C}=\text{CH}_2 + \text{H}_2\text{O} \xrightarrow{\text{H}^+}$ $\text{H}_3\text{C} \diagup$	III.	$\text{HCHO} + \text{CH}_3\text{COH}$
D.	$\text{H}_3\text{C} \diagdown \text{C}=\text{CH}_2 \xrightarrow{\text{KMnO}_4/\text{H}^+}$ $\text{H}_3\text{C} \diagup$	IV.	$(\text{CH}_3)_3\text{C} - \text{OH}$

Choose the correct answer from the options given below:

- A-II, B-IV, C-III, D-I
- A-II, B-III, C-IV, D-I
- A-II, B-III, C-I, D-IV
- A-IV, B-I, C-III, D-II

66 The technique used to purify liquids having high boiling points and getting decomposed at or below their boiling points is:

- fractional distillation
- steam distillation
- simple distillation
- distillation under reduced pressure

67 Match List-I with List-II

	List-I (Element)		List-II (Most Common oxidation state/s)
A.	Fe	I.	+2, +7
B.	V	II.	+3, +2
C.	Mn	III.	+4
D.	Ti	IV.	+5

Choose the correct answer from the options given below:

- A-II, B-IV, C-I, D-III
- A-IV, B-II, C-I, D-III
- A-II, B-I, C-IV, D-III
- A-I, B-IV, C-II, D-III

68 Match List-I with List-II

	List-I (Name of the reaction)		List-II (Name of the reaction)
A.	$\text{H}_2, \text{Nd} - \text{BaSO}_4$	I.	Gattermann-koch reaction
B.	$\text{CO}, \text{HCl}, \text{Anhyd. AlCl}_3/\text{CuCl}$	II.	Reimer-Tiemann reaction
C.	$\text{CO}, \text{HCl}, \text{Anhyd. AlCl}_3/\text{CuCl}$	III.	Etard reaction
D.	$\text{CHCl}_3, \text{NaOH}$	IV.	Rosenmund reduction

Choose the correct answer from the options given below:

- A-II, B-III, C-I, D-IV
- A-IV, B-III, C-I, D-II
- A-I, B-III, C-IV, D-II
- A-II, B-I, C-III, D-IV

**69** Given below are two statements:

<b>Statement I:</b>	<b>2 F</b> electricity is required for the oxidation of 1 mole $\text{H}_2\text{O}$ to $\text{O}_2$ .
<b>Statement II:</b>	To get <b>40.0 g</b> of Aluminium from molten $\text{Al}_2\text{O}_3$ required electricity is <b>4.44 F</b> .

In the light of the above statements, choose the correct answer from the options given below:

- Both **Statement I** and **Statement II** are true
- Both **Statement I** and **Statement II** are false
- Statement I** is true but **Statement II** is false
- Statement I** is false but **Statement II** is true

**70** Match List-I with List-II

List-I (Reagent)	List-II (name of the reaction)
A. Carbylamine test	I. phenol
B. Bayer's test	II. acetone
C. Iodoform test	III. ethylene
D. Phthalein dye test	IV. aniline

Choose the correct answer from the options given below:

- A-IV, B-III, C-II, D-I
- A-IV, B-II, C-III, D-I
- A-IV, B-II, C-I, D-III
- A-II, B-III, C-I, D-IV

**71** Which pair of the following compounds has one lone pair of electrons on the central atom?

- $\text{SF}_4$ ,  $\text{BrF}_5$
- $\text{SF}_4$ ,  $\text{ClF}_3$
- $\text{ClF}_3$ ,  $\text{XeF}_4$
- $\text{XeF}_4$ ,  $\text{BrF}_5$

**72** Match List-I with List-II

List-I (Reagent)	List-II (Name of the reaction)
A. $\text{Liquid} \rightleftharpoons \text{Vapour}$	I. Melting point
B. $\text{Solid} \rightleftharpoons \text{Liquid}$	II. Boiling point
C. $\text{Solid} \rightleftharpoons \text{Vapour}$	III. Sublimation point
D. $\text{Solute}(\text{solid}) \rightleftharpoons \text{Solute}(\text{solution})$	IV. Saturated solution
	V. Unsaturated solution

Choose the correct answer from the options given below:

- A-II, B-I, C-III, D-IV
- A-I, B-II, C-III, D-IV
- A-III, B-II, C-I, D-IV
- A-II, B-I, C-III, D-V

**73** Match List -I with List-II

List -I (Complex ion)	List -II (Hybridisation)
A. $[\text{Ni}(\text{CN})_4]^{2-}$	I. $sp^3$
B. $[\text{CoF}_6]^{3-}$	II. $d^2 sp^3$
C. $[\text{Co}(\text{C}_2\text{O}_4)_3]^{3-}$	III. $sp^3 d^2$
D. $(\text{NiCl}_4)^{2-}$	IV. $dsp^2$

Choose the correct answer from the options given below:

- A-IV, B-III, C-II, D-I
- A-III, B-I, C-IV, D-II
- A-I, B-II, C-III, D-IV
- A-III, B-IV, C-II, D-I

74

Identify [X] and [Y] in given reaction:

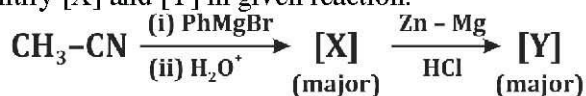

1.		$[\text{X}] = \text{Ph} \begin{array}{c} \text{O} \\ \parallel \\ \diagup \quad \diagdown \end{array} , [\text{Y}] = \text{Ph} \begin{array}{c} \text{OH} \\   \\ \diagup \quad \diagdown \end{array}$
2.		$[\text{X}] = \text{Ph} \begin{array}{c} \text{NH}_2 \\   \\ \diagup \quad \diagdown \end{array} , [\text{Y}] = \text{Ph} \begin{array}{c} \diagup \quad \diagdown \end{array}$
3.		$[\text{X}] = \text{Ph} \begin{array}{c} \text{O} \\ \parallel \\ \diagup \quad \diagdown \end{array} , [\text{Y}] = \text{Ph} \begin{array}{c} \diagup \quad \diagdown \end{array}$
4.		$[\text{X}] = \text{Ph} \begin{array}{c} \text{NH}_2 \\   \\ \diagup \quad \diagdown \end{array} , [\text{Y}] = \text{Ph} \begin{array}{c} \text{OH} \\   \\ \diagup \quad \diagdown \end{array}$

75 The common oxidation state shown by actinoids is +3 with the other oxidation states being +4, +3, +6, and +7. The number of oxidation states shown by the following elements decrease in the order:

- Np*(Z - 93)
- Am*(Z - 95)
- Ac*(Z - 89)
- Pa*(Z - 91)

Choose the correct answer from the options given below:

- A > B > D > C
- A > B > C > D
- B > A > D > C
- D > B > A > C

76 Match List-I with List-II

	List-I (Amine)		List-II (p <i>K<sub>b</sub></i> value)
A.	Benzenamine	I.	3.38
B.	Phenylmethanamine	II.	9.38
C.	Methenamine	III.	4.70
D.	N-Ethylethanamine	IV.	3.0

Choose the correct answer from the options given below:

- A-II, B-III, C-I, D-IV
- A-III, B-II, C-I, D-IV
- A-II, B-I, C-III, D-IV
- A-I, B-III, C-II, D-IV

77 Match List-I with List-II:

	List-I (Process/Property)		List-II (Characteristic)
A.	Adiabatic process	I.	Independent of amount of substance
B.	Reversible process	II.	Both way process reactant to product and vice-versa
C.	Intensive property	III.	No transfer of heat between system and surrounding
D.	Extensive property	IV.	Dependent on amount of substance

Choose the correct answer from the options given below:

- A-II, B-III, C-IV, D-I
- A-I, B-II, C-IV, D-III
- A-III, B-II, C-I, D-IV
- A-I, B-II, C-III, D-IV

78 Which of the following pair of aqueous solutions will have the same value of osmotic pressure? (Assume complete dissociation in aqueous solution)

- 0.1 M BaCl<sub>2</sub> and 0.2 M K<sub>2</sub>SO<sub>4</sub>
- 0.1 M Na<sub>3</sub>PO<sub>4</sub> and 0.1 M K<sub>2</sub>SO<sub>4</sub>
- 0.2 M NaCl and 0.1 M K<sub>2</sub>SO<sub>4</sub>
- 0.2 M NaCl and 0.1 M K<sub>3</sub>[Fe(CN)<sub>6</sub>]

- 79** The correct 'spin only' magnetic moments of  $[\text{CoF}_6]^{3-}$  and  $[\text{Co}(\text{C}_2\text{O}_4)_3]^{3-}$  respectively, are:
1. 0 BM and 4.9 BM
  2. 0 BM and 0 BM
  3. 4.9 BM and 0 BM
  4. 4.9 BM and 4.9 BM

- 80** The behaviour of samarium ( $Z=62$ ) is very much like europium ( $Z=63$ ). Since both elements:

1.	exhibit +2 and +3 oxidation states.
2.	have $4f^56s^2$ and $4f^66s^2$ electronic configurations, respectively.
3.	have $4f^76s^2$ and $4f^86s^2$ electronic configurations, respectively.
4.	have same atomic radii.

- 81** The correct shape and hybridisation of  $\text{BrF}_5$  is:

1. Square pyramidal and  $sp^3d^2$
2. Square pyramidal and  $d^2sp^3$
3. Trigonal bipyramidal and  $sp^3d^2$
4. Trigonal bipyramidal and  $d^2sp^3$

- 82** Match List-I with List-II :

List-I (Vitamins)	List-II (Deficiency/other name/property)
A. Vitamin K	I. RBC deficient in haemoglobin
B. Vitamin $B_{12}$	II. Bleeding gums
C. Vitamin C	III. Thiamine
D. Vitamin $B_1$	IV. Fat soluble

Choose the correct answer from the options given below:

1. A-I, B-II, C-III, D-IV
2. A-VI, B-III, C-II, D-I
3. A-I, B-IV, C-II, D-III
4. A-IV, B-I, C-II, D-III

- 83** Match List-I with List-II :

List-I (IUPAC official name)	List-II (IUPAC Symbol)
A. Mendeleevium	I. Mt
B. Meitnerium	II. Mc
C. Moscovium	III. No
D. Nobelium	IV. Md

Choose the correct answer from the options given below:

1. A-III, B-I, C-II, D-IV
2. A-IV, B-II, C-I, D-III
3. A-IV, B-I, C-II, D-III
4. A-I, B-IV, C-II, D-III

- 84** Effective collisions are known to possess:

- A: energy greater than threshold energy.  
 B: breaking of old bond in reactant.  
 C: formation of new bond in product.  
 D: high activation energy.  
 E: proper orientation.

Choose the correct answer from the options given below:

1. A, B, C, D only
2. A, B, C, E only
3. A, C, D, E only
4. B, C, D, E only

- 85**  $\text{CCl}_2\text{F}_2$  is one of the most common haloalkanes used in

industries. The reaction through which it is manufactured from tetrachloromethane is called:

1. Finkelstein reaction
2. Sandmeyer's reaction
3. Swarts reaction
4. Wurtz-Fittig reaction

**86** The product that cannot be formed in the following reaction is:

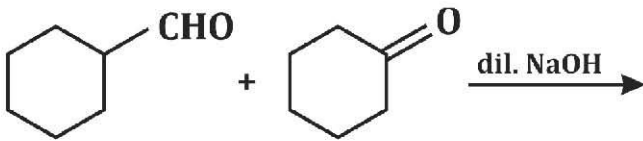

1.	
2.	
3.	
4.	

**87** Number of moles of  $\text{MnO}_4^-$  getting reduced to  $\text{Mn}^{2+}$  under acidic condition by  $4.517 \times 10^{24}$  electrons is:

1. 1.5 moles
2. 7.5 moles
3. 2.5 moles
4. 5.0 moles

**88** The most preferred method for the preparation of pure alkyl chlorides from alcohols is:

1.  $\text{R-OH} + \text{HCl} \xrightarrow{\text{ZnCl}_2} \text{R-Cl} + \text{H}_2\text{O}$
2.  $\text{R-OH} + \text{PCl}_5 \rightarrow \text{R-Cl} + \text{POCl}_3 + \text{HCl}$
3.  $\text{R-OH} + \text{SOCl}_2 \rightarrow \text{R-Cl} + \text{SO}_2 + \text{HCl}$
4.  $\text{R-OH} + \text{PCl}_3 \rightarrow \text{R-Cl} + \text{H}_3\text{PO}_3$

**89** In salt analysis group V radicals ( $\text{Ba}^{2+}$ ,  $\text{Ca}^{2+}$  and  $\text{Sr}^{2+}$ ) are precipitated as their carbonates

by adding solid  $\text{NH}_4\text{Cl}$  and excess of  $\text{NH}_4\text{OH}$  solution followed by solid  $(\text{NH}_4)_2\text{CO}_3$

Choose the correct reagent used for the confirmation of  $\text{Ca}^{2+}$  ion from the following:

1. Ammonium sulphate
2. Potassium chromate
3. Ammonium oxalate
4. Ammonium nitrate

**90** The major product P formed in the following reaction sequence is :

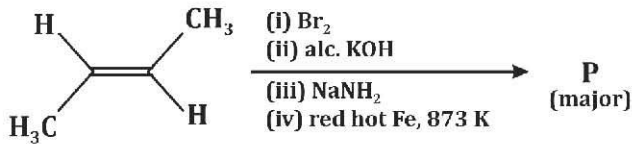

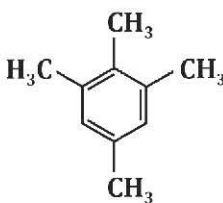
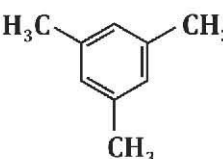
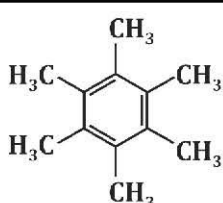
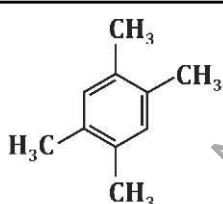
1.	
2.	
3.	
4.	

**91** Identify the Incorrect statement:

1.	Carbon has the tendency to form chains and rings with itself.
2.	Silicon and Germanium are useful in semiconductor industry.
3.	Boron trifluoride is a strong Lewis acid.
4.	Common oxidation states of group 14 elements are +1 and +3.

**92** When 5 g of non-volatile non-electrolyte solute is dissolved in 100 g of a certain solvent, the freezing point of the solvent decreases by 0.25 K. The molar mass of the solute is:

[ $K_f$  of the given solvent =  $1.2\text{K kg mol}^{-1}$ ]

- 242.8  $\text{g mol}^{-1}$
- 238.2  $\text{g mol}^{-1}$
- 241.8  $\text{g mol}^{-1}$
- 240.0  $\text{g mol}^{-1}$

**93** The time taken by the first order decomposition of  $\text{SO}_2\text{Cl}_2$  to decompose to 40% is 560 seconds. The rate constant for the reaction is:

( $\log 2.5 = 0.3979$ )

- $2.726 \times 10^{-5} \text{ min}^{-1}$
- $2.276 \times 10^{-5} \text{ min}^{-1}$
- $2.216 \times 10^{-5} \text{ min}^{-1}$
- $2.126 \times 10^{-5} \text{ min}^{-1}$

**94** Identify the incorrect statement:

1.	The relative stability of group 13 elements in +1 oxidation state varies as : $\text{Al} < \text{Ga} < \text{In} < \text{Tl}$ .
2.	Boron trioxide is acidic, aluminium and gallium trioxides are amphoteric while indium and thallium trioxides are basic.
3.	The hybridisation of Al in $[\text{Al}(\text{H}_2\text{O})_6]^{3+}$ is $d^2 sp^3$ .
4.	Two isotopes of Boron, namely $^{10}\text{B}$ (19%) and $^{11}\text{B}$ (81%) are known.

**95** Given below are two statements:

<b>Statement I:</b>	Benzediazonium chloride is a colourless crystalline solid. It is insoluble in water but reacts with water when warmed.
<b>Statement II:</b>	Benzediazonium chloride on reacting with HCl in presence of copper powder gives chlorobenzene as the product. This is an example of Gatterman reaction.

In the light of the above statements, choose the correct answer from the option given below:

- Both **Statement I** and **Statement II** is true.
- Both **Statement I** and **Statement II** is false.
- Statement I** is true but **Statement II** is false.
- Statement I** is false but **Statement II** is true.

**96** The compound that gives blood red colour in Lassaigne's test is:

1.		2.	
3.		4.	

**97** Enthalpy of combustion of carbon to carbon dioxide is  $-390.0 \text{ kJ mol}^{-1}$ . The amount of heat released when **35.0 g** of  $\text{CO}_2$  is formed from the reaction of carbon and dioxygen gas, is:

1. 310 kJ
2. 490 kJ
3. 245 kJ
4. 700 kJ

**98** For the equilibrium



the value of the equilibrium constant is  $3.0 \times 10^{-6}$  at **1000 K**. Find  $K_p$  for the reaction at this temperature (Given  $R : 8.314 \text{ J K}^{-1} \text{ mol}^{-1}$ )

1. 1.493
2.  $2.494 \times 10^{-2}$
3.  $3.0 \times 10^{-6}$
4.  $2.494 \times 10^{-4}$

**99** The Crystal Field Stabilisation Energy (CFSE) and the 'spin only' magnetic moment of  $[\text{FeF}_6]^{3-}$  ion respectively, are:

1.  $0 \Delta$  and 5.9 BM
2.  $0 \Delta$  and 1.73 BM
3.  $2.0 \Delta$  and 5.9 BM
4.  $2.0 \Delta$  and 1.73 BM

**100** In salt analyses,  $\text{Cl}^-$ ,  $\text{Br}^-$  and  $\text{I}^-$  are identified by adding dilute  $\text{HNO}_3$  followed by  $\text{AgNO}_3$  solution to the salt solution. Choose the correct statements from the following.

A.	$\text{Cl}^-$ gives pale yellow precipitate.
B.	$\text{Br}^-$ gives pale yellow precipitate which is partially soluble in $\text{NH}_4\text{OH}$ .
C.	$\text{I}^-$ gives yellow precipitate which is insoluble in $\text{NH}_4\text{OH}$ .
D.	$\text{Cl}^-$ gives white precipitate which is insoluble in $\text{NH}_4\text{OH}$ .
E.	$\text{I}^-$ gives purple violet gas.

Choose the correct answer from the options given below:

1. B and C only
2. A and B only
3. A and E only
4. D and E only

**101** Given below are two statements:

<b>Statement I:</b>	Rain forests which used to cover more than 14% of the earth's land surface is now reduced to 6%.
<b>Statement II:</b>	Amazon rain forest has greatest biodiversity on earth.

In the light of the above statements, choose the correct answer from the options given below:

1. Both Statement I and Statement II are true
2. Both Statement I and Statement II are false
3. Statement I is true but Statement II is false
4. Statement I is false but Statement II is true



**102** Read the following statements and choose the set of correct statements :

A.	In cymose inflorescence, the flowers are borne in an acropetalous succession.
B.	In gulmohar, the flowers are actinomorphic.
C.	In the flowers of cucumber, the margin of the thalamus grows upward enclosing the ovary completely and getting fused with it, the other parts of flowers arise above the ovary.
D.	Bracts are reduced leaves found at the base of the pedicle.
E.	The flowers are hypogynous in mustard.

Choose the correct answer from the options given below

1. A, B, C only
2. B, D, E only
3. A, C, D only
4. C, D, E only

**103** 'Golden rice' is a genetically modified rice. It is an example of

1. Bioprospecting
2. Biofortification
3. Pest-resistant crop
4. Increased mineral usage efficiency

**104** Which of the following statement is incorrect about enzymes?

1.	They are highly substrate specific
2.	In thermophilic organisms enzymes can catalyze reaction at high temperatures i.e. 90°C
3.	All enzymes are proteinaceous in nature
4.	Some enzymes have metal ions

**105** In plants, sucrose is converted into two molecules of monosaccharides due to action of invertase and then both enter the glycolytic pathway. Identify the monosaccharides.

1. Glucose and glucose
2. Glucose and fructose
3. Glucose and galactose
4. Fructose and galactose

**106** Given below are two statements:

<b>Statement I:</b>	Two DNA sequences were prepared corresponding to A and B, chains of human insulin and were introduced in the plasmids of <i>Agrobacterium</i> to produce insulin chain.
<b>Statement II:</b>	Chain A and B were produced separately, extracted and combined by creating disulphide bonds to form human insulin.

In the light of the above statements, choose the correct answer from the options given below.

1. Both Statement I and Statement II are true
2. Both Statement I and Statement II are false
3. Statement I is true but Statement II is false
4. Statement I is false but Statement II is true

**107** The junction between ovule and funicle is represented by :

1.	Nucellus	2.	Integument
3.	Chalaza	4.	Hilum

**108** The photochemical phase of photosynthesis include:

- A. Oxygen release
- B. Formation of NADPH
- C. Use of ATP
- D. Water splitting
- E. Carboxylation

Choose the correct answer from the options given below:

1. C and E only
2. A, B and D only
3. B, C and E only
4. A, B, C and D only

**109** ABO blood group is an example of

1. Incomplete dominance
2. Multiple alleles
3. Pleiotropy
4. Linkage

**110** The negatively geotropic roots produced by *Rhizophora* are called:

1. Pneumatophores
2. Prop roots
3. Stilt roots
4. Storage roots

**111** Match List-I with List-II

	List-I		List-II
A.	C <sub>4</sub> Pathway	I.	$2\text{H}_2\text{O} \rightarrow 4\text{H}^+ + \text{O}_2 = 4\text{e}^-$
B.	Light reaction	II.	Ribulose 1,5-bisphosphate
C.	Photorespiration	III.	Phosphoenol Pyruvate
D.	Calvin cycle	IV.	Phosphoglycolate

Choose the correct answer from the options given below :

1. A-II, B-I, C-IV, D-III
2. A-IV, B-II, C-I, D-III
3. A-III, B-I, C-IV, D-II
4. A-III, B-IV, C-II, D-I

**112** Cell wall formation in Bacteria is facilitated by :

1. Ribosomes
2. Mesosomes
3. Golgi Apparatus
4. Centrosomes

**113** A cross between tall plants was made resulting in offspring of tall and dwarf plants with ratio 3 : 1. The genotype(s) of both parents are:

1. TT and TT
2. Tt and tt
3. Tt and Tt
4. tt and tt

**114** The asexual spores of Deuteromycetes are:

1. Aplanospores
2. Conidia
3. Zoospores
4. Basidiospores

**115** The following can be found as a zwitter ion:

1. Fatty acid
2. Monosaccharide
3. Amino acid
4. Nucleic acid

**116** Which of the following represent Sister-chromatids in the given figure?

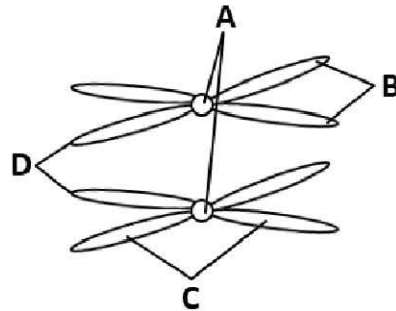

1. A
2. B
3. C
4. D

**117** Which of the following represents the female gametophyte?

1. Ovule
2. Embryo sac
3. Nucellus
4. Endosperm

**118** Which of the following is not a selectable marker of cloning vectors?

1. Ampicillin
2. Metformin
3. Chloramphenicol
4. Tetracycline

**119** Which of the following is not the characteristic feature of genetic code?

1. The codon is triplet
2. The code is nearly universal
3. The code has punctuations
4. Some amino acids are coded by more than one codon, hence the code is degenerate

**120** Given below are two statements :

<b>Statement I:</b>	When the fitness of one species is significantly lower in the presence of another species, the process is defined as competition.
<b>Statement II:</b>	When fungi remain in association with living plants or animals they are called saprophytes.

In the light of the above statements, choose the correct answer from the options given below :

- Both **Statement I** and **Statement II** are True
- Both **Statement I** and **Statement II** are False
- Statement I** is True but **Statement II** is False
- Statement I** is False but **Statement II** is True

**121** Which of the following is not a complex polysaccharide?

- Inulin
- Chitin
- Glucosamine
- N-acetyl galactosamine

**122** The population growing in a habitat with limited resources will show:

A.	Lag phase, followed by phases of acceleration and deceleration and finally an asymptote.
B.	The ability to realise its innate potential to grow in number and reach enormous densities in short time.
C.	Exponential growth
D.	Logistic growth

Choose the correct answer from the option given below:

- A and B only
- C and D only
- A and D only
- B and C only

**123** Which of the following technique was used to elucidate the double helix model of DNA?

- $\gamma$ -radiation
- Electromagnetic radiation
- UV-vis spectroscopy
- X-ray diffraction

**124** How many molecules of ATP and NADPH are required respectively for fixation of every  $\text{CO}_2$  molecule entering the Calvin cycle?

- 2 and 4
- 4 and 2
- 3 and 2
- 2 and 3

**125** In glycolysis, the conversion of 1, 3-bisphosphoglyceric Acid to 3-phosphoglyceric Acid is:

- Energy yielding process
- Energy utilising process
- Phosphorylation process
- Isomerisation process

**126** The transverse section of monocot root shows the following internal tissue organization. Arrange them in correct sequence starting from periphery to centre.

- Endodermis
- Pith
- Epidermis
- Pericycle
- Cortex

Choose the correct answer from the options given below:

- D, C, E, A, B
- A, C, E, B, D
- C, E, A, D, B
- C, E, D, B, A

**127** Match List-I with List-II

List-I		List-II
A. Toxin	I.	Gum
B. Polymeric substance	II.	Concanavalin A
C. Lectin	III.	Ricin
D. Drug	IV.	Vinblastin

Choose the correct answer from the options given below:

- A-III, B-IV, C-II, D-I
- A-II, B-IV, C-I, D-III
- A-III, B-I, C-II, D-IV
- A-II, B-I, C-IV, D-III

**128** A yellow seeded and violet flowered pea plant was crossed with a green seeded and white flowered pea plant. The progeny showed plants with four different phenotypes. The yellow seeded and violet flowered parent must be:

- Double homozygous
- Double heterozygous
- Homozygous for seed colour and heterozygous for flower colour.
- Heterozygous for seed colour and homozygous for flower colour.

**129** Identify the place(s) from the following where sacred groves are not found.

- A. Aravalli Hills of Rajasthan.
- B. Chanda and Bastar area of Madhya Pradesh.
- C. Mudumalai Sanctuary in Tamil Nadu.
- D. Khasi and Jaintia Hills in Meghalaya.

Choose the correct answer from the options given below:

- 1. A only
- 2. C only
- 3. B and C only
- 4. C and D only

**130** Match List-I with List-II

List-I	List-II
A. Microscopic angiosperm	I. <i>Salvinia</i>
B. Tallest gymnosperm	II. <i>Marchantia</i>
C. Thalloid bryophyte	III. <i>Sequoia</i>
D. Heterosporous pteridophyte	IV. <i>Wolffia</i>

Choose the correct answer from the options given below :

- 1. A-I, B-III, C-II, D-IV
- 2. A-IV, B-III, C-II, D-I
- 3. A-III, B-II, C-IV, D-I
- 4. A-II, B-I, C-IV, D-III

**131** The given figure with reference to the anatomy of plants represents:



- 1. Tracheid
- 2. Xylem fibre
- 3. Xylem parenchyma
- 4. Vessel

**132** Match List-I with List-II.

List-I	List-II
A. Polyadelphous	I. Filaments of stamens united into more than two bundles
B. Syncarpous	II. Sterile stamen
C. Staminode	III. Stamens are attached to the petals
D. Epipetalous	IV. Carpels are fused

Choose the correct answer from the options given below:

- 1. A-I, B-IV, C-II, D-III
- 2. A-II, B-I, C-III, D-IV
- 3. A-II, B-III, C-I, D-IV
- 4. A-I, B-II, C-IV, D-III

**133** Synthesis of ATP linked to development of a proton gradient across a membrane is:

- 1. Mass flow hypothesis
- 2. Wobble hypothesis
- 3. Chemiosmotic hypothesis
- 4. Rivet Popper hypothesis

**134** Important objective of biotechnology in agriculture is to.

- 1. produce pest resistant varieties of plant.
- 2. increase nitrogen content in plant.
- 3. decrease the seed number.
- 4. increase the plant weight.

**135** The phenomenon where a single gene exhibiting multiple phenotypic expressions is called:

- 1. Co-dominance
- 2. Pleiotropy
- 3. Multiple alleles
- 4. Polygenic inheritance

**136** Given below are two statements:

<b>Statement I:</b>	In collenchyma cell walls are thickened at corners due to deposition of cellulose, hemicellulose and pectin.
<b>Statement II:</b>	Sclerenchyma consists of lignified cell walls and possesses pits.

In the light of the above statements, choose the correct answer from the options given below:

- 1. Both **Statement I** and **Statement II** are True
- 2. Both **Statement I** and **Statement II** are False
- 3. **Statement I** is True but **Statement II** is False
- 4. **Statement I** is False but **Statement II** is True

**137** *Bt* toxin protein that can kill many insects, doesn't kill the *Bacillus* because:

1. *Bt* toxin requires acidic pH for activation
2. *Bacillus* has protective mechanism against it
3. In *Bacillus*, it is present in an inactive state and once insects ingest it, it is converted to active form
4. The protoxin requires protein conjugate for its activation

**138** Which of the following graphs explains the effect of pH on the enzyme activity?

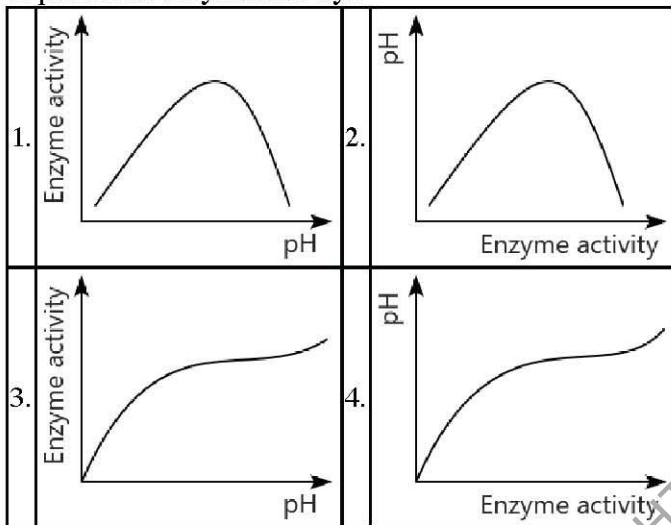

**139** Highest annual Net Primary Productivity is observed in:

1. Tropical deciduous forest
2. Temperate evergreen forest
3. Temperate deciduous forest
4. Tropical rain forest

**140** In the *lac* operon the *i* gene codes for:

1. Inducer
2. Repressor
3.  $\beta$ -galactosidase
4. Permease

**141** Given below are two statements

Statement I : The rate of decomposition is not related to chemical composition of detritus and climatic factors.

Statement II : In a particular climatic condition, decomposition rate is faster if detritus is rich in lignin and chitin.

In the light of the above statements, choose the correct answer from the options given below:

1. Both Statement I and Statement II are True
2. Both Statement I and Statement II are False
3. Statement I is True but Statement II is False
4. Statement I is False but Statement II is True

**142** Which of the following is not an example of Mutualism?

1. Lichens
2. Mycorrhizae
3. An orchid on a branch of mango plant
4. The wasp pollinating fig inflorescence

**143** Which experimental material was used by Taylor and colleagues to prove that DNA in chromosomes replicates semiconservatively?

1. *Vicia faba*
2. *Pisum sativum*
3. *Solanum tuberosum*
4. *Oryza sativa*

**144** Match List-I with List-II

	List-I		List-II
A	Ethylene	I	Increase length of stem
B	Cytokinins	II	Promotion of senescence and abscission
C	ABA	III	Delaying leaf senescence
D	Gibberellins	IV	Inhibition of seed germination

Choose the correct answer from the options given below:

1. A-III, B-I, C-IV, D-II
2. A-II, B-III, C-IV, D-I
3. A-IV, B-II, C-I, D-III
4. A-III, B-IV, C-I, D-II

**145** Given below are two statements:

<b>Statement I:</b>	Restriction Endonuclease finds its specific recognition sequence and binds to the DNA.
<b>Statement II:</b>	Restriction Endonuclease cuts each of the two strands of the double helix at specific points in their sugar phosphate backbones.

In the light of the above statements, choose the correct answer from the options given below:

- Both **Statement I** and **Statement II** are True
- Both **Statement I** and **Statement II** are False
- Statement I** is True but **Statement II** is False
- Statement I** is False but **Statement II** is True

**146** Match List-I with List-II

List-I	List-II
A Collagen	I Enzyme
B GLUT-4	II Most abundant enzyme in biosphere
C Trypsin	III Most abundant protein in animal world
D RuBisCO	IV Enables glucose transport into cells

Choose the correct answer from the options given below:

- A-III, B-I, C-IV, D-II
- A-II, B-III, C-I, D-IV
- A-III, B-IV, C-I, D-II
- A-I, B-III, C-IV, D-II

**147** What is incorrect about ecosystem?

1. It can vary from small sized pond to large sized sea
2. It may be anthropogenic in origin
3. It may be temporary or Permanent
4. It involves the function of flow of energy but not recycling of nutrients

**148** The flowers of *Amorphophallus* provide safe place for the pollinator to lay eggs. This is an example of:

- Amensalism
- Anemophily
- Floral reward
- Commensalism

**149** Read the following statements and find out the correct set of statements:

A.	Companion cells help in maintaining the pressure gradient in the sieve tubes.
B.	Gymnosperms lack vessels in their xylem
C.	The xylem vessels are devoid of cytoplasm
D.	Xylem fibres may be septate or aseptate
E.	A mature sieve element in phloem possesses cytoplasm, vacuole and nucleus.

Choose the correct answer from the options given below:

- B, C, D, E only
- A, B, D, E only
- A, B, C, D only
- C, D, E only

**150** Which of the following statements are correct about respiration?

A.	Energy of oxidation-reduction is utilised for phosphorylation
B.	Oxygen acts as the final hydrogen acceptor
C.	The photo-oxidative energy is utilised for production of proton gradient required for phosphorylation
D.	The role of oxygen is limited to the terminal stage of the respiration process
E.	Protons cross the outer membrane of mitochondria through the channel formed by an integral membrane protein complex

Choose the correct answer from the options given below:

- A, B, C, E only
- A, B, D only
- B, C, D, E only
- A, C, D only

**151** Match List-I with List-II

List-I	List-II
1. DNA fingerprinting	I. M. Meselson and F. Stahl
2. <i>Pneumococcus</i>	II. A Harshey and M. Chase
3. <i>E.coli</i>	III. F. Griffith
4. Bacteriophage	IV. Alec Jeffreys

Choose the correct answer from the options given below:

- A-IV, B-III, C-II, D-I
- A-IV, B-III, C-I, D-II
- A-II, B-III, C-I, D-IV
- A-III, B-II, C-I, D-IV

**152**

<b>Statement I:</b>	The ground substance of bone is solid, pliable and resist compression.
<b>Statement II:</b>	The bone marrow of all bones is site of production of blood cells.

In the light of the above statements, choose the most appropriate answer from the options given below.

- Both **Statement I** and **Statement II** are correct
- Both **Statement I** and **Statement II** are incorrect.
- Statement I** is correct but **Statement II** is incorrect
- Statement I** is incorrect but **Statement II** is correct

**153** Arrange in a proper sequence the pathway of sperms from testis to outside in human male reproductive system.

- Vas deferens
- Rete testis
- Seminiferous tubules
- Vasa efferentia
- Urethra
- Epididymis

Choose the correct answer from the options given below :

- F** → **A** → **B** → **D** → **E** → **C**
- C** → **A** → **B** → **D** → **F** → **E**
- B** → **A** → **D** → **C** → **F** → **E**
- C** → **B** → **D** → **F** → **A** → **E**

**154** Match List-I with List-II:

	List-I		List-II
A.	Tertiary consumer	I.	Grass
B.	Secondary consumer	II.	Lion
C.	Primary consumer	III.	Wolf
D.	Primary producer	IV.	Goat

Choose the correct answer form the options given below:

- A-I, B-II, C-III, D-IV
- A-III, B-IV, C-II, D-I
- A-III, B-II, C-IV, D-I
- A-II, B-III, C-IV, D-I

**155** Given below are two statements:

<b>Statement I:</b>	Bacterial infection by <i>Bacillus thuringiensis</i> can kill only caterpillar larvae.
<b>Statement II:</b>	<i>B. thuringiensis</i> cannot kill adult moths.

In the light of the above statements, choose the most appropriate answer from the options given below:

- Both **Statement I** and **Statement II** are correct.
- Both **Statement I** and **Statement II** are incorrect.
- Statement I** is correct but **Statement II** is incorrect
- Statement I** is incorrect but **Statement II** is correct.

**156** Match List I with List II relating to major features of embryonic development at different timings of pregnancy:

	List-I (No. of weeks)		List-II (Major features)
A.	After 4 weeks of pregnancy	I.	Eye-lids separate and eyelashes are formed
B.	After 12 weeks of pregnancy	II.	Heart is formed
C.	After 24 weeks of pregnancy	III.	Limbs and digits are developed
D.	After 8 weeks of pregnancy	IV.	External genital organs are well developed

Choose he correct answer from the options given below:

- A-III, B-IV, C-I, D-II
- A-II, B-I, C-III, D-IV
- A-II, B-IV, C-I, D-III
- A-III, B-IV, C-II, D-I

**157** Match List-I with List-II:

	List-I		List-II
A	<i>Saccharomyces cerevisiae</i>	I.	Citric acid
B.	<i>Aspergillus niger</i>	II.	Butyric acid
C.	<i>Trichoderma polysporum</i>	III.	Ethanol
D.	<i>Clostridium butylicum</i>	IV.	Cyclosporin-A

Choose the correct answer from the options :

- A-III, B-I, C-IV, D-II
- A-IV, B-II, C-III, D-I
- A-III, B-IV, C-I, D-II
- A-I, B-III, C-II, D-IV

**158** The animal coelacanth caught in South Africa is an example of vertebrate transition from:

1. Fish to Amphibia
2. Amphibia to Reptilia
3. Reptilia to Bird
4. Reptilia to Mammal

**159** Identify the correct statements about Genetic codons.

- A. AUG is initiator codon and codes for Glycine
  - B. UAA codes for Tyrosine
  - C. The codons are mostly universal
  - D. UAG is terminator codon
  - E. More than one codons code for single amino acid
1. C, B, D
  2. A, D, E
  3. C, D, E
  4. A, B, C

**160** Match List-I with List-II

	List-I		List-II
A.	Emphysema	I.	Proliferation of fibrous tissues
B.	Asbestosis	II.	Alveolar walls are damaged and respiratory surface is decreased
C.	Asthma	III.	Serious lung damage
D.	Fibrosis	IV.	Difficulty in breathing due to inflammation of bronchi and bronchioles

Choose the correct answer from the options given below:

1. A-I, B-III, C-IV, D-II
2. A-II, B-III, C-IV, D-I
3. A-IV, B-III, C-II, D-I
4. A-I, B-II, C-IV, D-III

**161** Which of the following group of animals have three chambered heart?

1. *Bufo*, *Alligator*, *Struthio*
2. *Chameleon*, *Hyla*, *Calotes*
3. *Crocodilus*, *pavo*, *Clarias*
4. *Exocoetus*, *Hemidactylus*, *Rana*

**162** Which of the following is 'NOT' an autosomal recessive disorder?

1. Sickle cell anemia
2. Phenylketonuria
3. Haemophilia
4. Thalassemia

**163** Given below are two statements : One is labelled as Assertion (A) and the other is labelled as Reason (R).

<b>Assertion (A):</b>	In honey bee population, sons do not have fathers but have grandfathers.
<b>Reason (R):</b>	Haploidy in drones of honey bee is due to parthenogenesis while fertilisation results into female bees.

In the light of the above statements, choose the correct answer from the options given below:

1.	Both (A) and (R) are True and (R) is the correct explanation of (A).
2.	Both (A) and (R) are True but (R) is not the correct explanation of (A).
3.	(A) is True but (R) is False.
4.	(A) is False but (R) is True.

**164** In standard ECG diagram, the P-wave represents:

1. Depolarisation of the atria
2. Repolarisation of the ventricle
3. Depolarisation of the ventricle
4. End of systole

**165** Name the hormone(s) not secreted by placenta.

- A. Estrogens
- B. Progestogens
- C. Relaxin and Inhibin
- D. hCG
- E. hPL

Choose the correct answer from the options given below:

1. D and E only
2. C only
3. B only
4. A and C only

**166** MTP (Medical Termination of Pregnancy) with oral pills is considered relatively safe upto:

1. 7-9 weeks of pregnancy
2. 15-18 weeks of pregnancy
3. 20-24 weeks of pregnancy
4. 28-30 weeks of pregnancy

**167** Use of hyper immune horse serum raised against a specific pathogen, given to a recipient is an example of:

1. Natural active immunity
2. Artificial active immunity
3. Natural passive immunity
4. Artificial passive immunity



**168**

Match List-I with List-II:

	List-I		List-II
A.	Ribozyme	I.	Glucose transport
B.	Lecithin	II.	Non proteinaceous enzyme
C.	Glut-4	III.	Lipid
D.	Vitamins	IV.	Coenzyme

Choose the correct answer from the options given below :

1. A-IV, B-III, C-I, D-II
2. A-IV, B-III, C-II, D-I
3. A-II, B-I, C-III, D-IV
4. A-II, B-III, C-I, D-IV

**169** Match List-I with List-II.

	List-I		List-II
A.	Cilia	I.	Spindle fibres
B.	Endoplasmic Reticulum	II.	Cristae
C.	Mitochondria	III.	Axoneme
D.	Kinetochores	IV.	Ribosomes

Choose the correct answer from the options given below:

1. A-I, B-IV, C-II, D-III
2. A-III, B-IV, C-II, D-I
3. A-I, B-III, C-II, D-IV
4. A-III, B-II, C-I, D-IV

**170** Match List-I with List-II:

	List-I		List-II
A.	Tricuspid valves	I.	Guards the opening between right atrium and right ventricle
B.	Sino-atrial node	II.	Guards the opening between the left atrium and the left ventricle
C.	Mitral valves	III.	Guards the opening of right and left ventricles into pulmonary artery and aorta, respectively
D.	Semilunar valves	IV.	Cardiac musculature in the right upper corner of right atrium

Choose the correct answer from the options given below :

1. A-III, B-IV, C-II, D-I
2. A-II, B-I, C-IV, D-III
3. A-III, B-IV, C-I, D-II
4. A-I, B-IV, C-II, D-III

**171** Given below are two statements:

<b>Statement I:</b>	Aphids and mosquitoes are natural pests.
<b>Statement II:</b>	Lady bird and dragonflies are natural pests controllers.

In the light of the above statements , choose the most appropriate answer from the options given below:

1. Both **Statement I** and **Statement II** are correct
2. Both **Statement I** and **Statement II** are incorrect
3. **Statement I** is correct but **Statement II** is incorrect.
4. **Statement I** is incorrect but **Statement II** is correct

**172** Match List-I with List-II

	List-I		List-II
A.	Ampicillin	I.	Restriction sites
B.	Ori	II.	Blue/White screening
C.	Multiple cloning sites	III.	Selectable marker
D.	$\beta$ galactosidase gene	IV.	Sequence from where replication starts

Choose the correct answer from the options given below:

1. A-III, B-IV, C-I, D-II
2. A-III, B-I, C-IV, D-II
3. A-IV, B-III, C-II, D-I
4. A-II, B-IV, C-I, D-III

**173** Match List-I with List-II

	List-I		List-II
A.	Vertebrochondral Ribs	I.	Ilium , Ischium Pubis
B.	Floating Ribs	II.	8 <sup>th</sup> , 9 <sup>th</sup> and 10 <sup>th</sup> Pairs
C.	Scapula	III.	Acromion
D.	Coxal Bone	IV.	11 <sup>th</sup> and 12 <sup>th</sup> Pairs

Choose the correct answer from the options given below:

1. A-I, B-III, C-II, D-IV
2. A-III, B-IV, C-II, D-I
3. A-II, B-IV, C-III, D-I
4. A-I, B-IV, C-II, D-III

**174** Which part of human nephron impermeable to water?

1. Proximal convoluted tubule
2. Distal convoluted tubule
3. Ascending limb of loop of Henle
4. Descending limb of loop of Henle

**175** In the following diagram of alimentary canal of cockroach identify the labels A, B, C and D respectively.

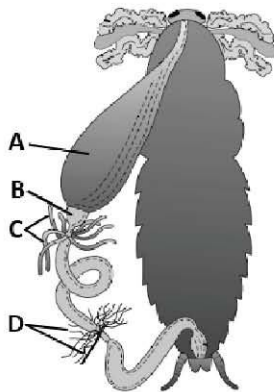

1. A-Gizzard, B-Crop, C-Malpighian tubules, D-Hepatic caeca
2. A-Oesophagus, B-Crop, C-salivary glands, D-Hepatic caeca
3. A-Crop, B-Gizzard, C-Hepatic caeca, D-Malpighian tubules
4. A-Gizzard, B-Hepatic caeca, C-Malpighian tubules, D- Cilia

**176** Match List-I with List-II:

	List-I		List-II
A.	Limbic system	I.	Body temperature
B.	Arachnoid	II.	Tract of nerve fibres
C.	Corpus callosum	III.	Amygdala
D.	Hypothalamus	IV.	Cranial meninge

Choose the correct answer from the options given below:

1. A-III, B-IV, C-II, D-I
2. A-I, B-II, C-IV, D-III
3. A-II, B-I, C-III, D-IV
4. A-IV, B-II, C-III, D-I

**177** Which of the following is NOT an example of assisted reproductive technology (ART) ?

1. IVF
2. GIFT
3. IUI
4. IUD

**178** Given below are two statements : One is labelled as Assertion (A) and the other is labelled as Reason (R).

<b>Assertion (A):</b>	Some ethical standards are required to evaluate the morality of scientific human activities that might help or harm living organisms.
<b>Reason (R):</b>	Genetic Engineering Approval Committee make decisions regarding the validity of Genetically Modified (GM) research and the safety of introducing GM organisms for public services.

In the light of the above statements choose the most appropriate answer from the options given below :

1.	Both (A) and (R) are correct and (R) is the correct explanation of (A).
2.	Both (A) and (R) are correct but (R) is not the correct explanation of (A).
3.	(A) is correct but (R) is not correct
4.	(A) is not correct but (R) is correct.

**179** Match List-I with List-II:

	List-I		List-II
A	Parathyroid hormone	I.	Flight or fight response
B.	Epinephrine and Nor-epinephrine	II.	Regulates the body's biological clock
C.	Thyroid stimulating hormone	III.	Increases blood $Ca^{2+}$ level
D.	Melatonin	IV.	Synthesis of $T_3$ and $T_4$ hormones

Choose the correct answer from the options given below :

1. A-III, B-I, C-IV, D-II
2. A-III, B-IV, C-I, D-II
3. A-III, B-I, C-II, D-IV
4. A-I, B-II, C-III, D-IV

**180** The catalytic cyclic of an enzyme action is described as:

- A. Enzyme releases products of the reaction and gets free.  
 B. Substrate induces the enzyme to alter its shape.  
 C. The substrate binds with the active site of the enzyme.  
 D. Enzymes-product complex is formed.
1.  $C \rightarrow B \rightarrow A \rightarrow D$
  2.  $C \rightarrow B \rightarrow D \rightarrow A$
  3.  $B \rightarrow C \rightarrow D \rightarrow A$
  4.  $D \rightarrow C \rightarrow A \rightarrow B$

**181** Match List-I with List-II:

	List-I (Biological Name)		List-II (Common name)
A.	<i>Asterias</i>	I.	Sea urchin
B.	<i>Antedon</i>	II.	Brittle star
C.	<i>Echinus</i>	III.	Sea lily
D.	<i>Ophiura</i>	IV.	Star fish

Choose the correct answer from the options given below:

1. A-III, B-IV, C-II, D-I
2. A-IV, B-III, C-I, D-II
3. A-II, B-III, C-I, D-IV
4. A-I, B-II, C-IV, D-III

**182** Given below is a list of some sexually reproducing animals. Select the hermaphrodite animals from the list.

- A. Cockroach  
 B. Leech  
 C. Housefly  
 D. Tapeworm  
 E. Earthworm

Choose the correct answer form options given below :

1. A, B and D only
2. C and D only
3. B, D and E only
4. A, C and E only

**183** Given below are two statements: One is labelled as

Assertion (A) and the other is labelled as Reason (R).

<b>Assertion (A):</b>	The interaction, in which one species benefits and the other is neither harmed nor benefitted, is known as commensalism.
<b>Reason (R):</b>	Egrets always forage close to where the cattles are grazing, otherwise it is difficult for the egrets to find the insect and catch.

In the light of the above statements, choose the correct answer from the options given below:

1.	Both (A) and (R) are True and (R) is the correct explanation of (A).
2.	Both (A) and (R) are True but (R) is not the correct explanation of (A).
3.	(A) is True but (R) is False
4.	(A) is False but (R) is True.

**184** Match List-I with List-II:

	List-I (Cell Cycle)		List-II (Events)
A.	$G_1$ phase	I.	Cell is metabolically active but no proliferation until required
B.	S phase	II.	Replication of DNA
C.	$G_0$ stage	III.	Synthesis of proteins
D.	$G_2$ phase	IV.	Cell is metabolically active and grows continuously

Choose the correct answer from the options given below :

1. A-I, B-II, C-IV, D-III
2. A-IV, B-II, C-I, D-III
3. A-II, B-IV, C-I, D-III
4. A-I, B-III, C-II, D-IV

**185** Given below are two statements : One is labelled as Assertion (A) and the other is labelled as Reason (R).

<b>Assertion (A):</b>	Connell's elegant field experiment showed that on the rocky sea, the larger and competitively superior barnacles dominate the intertidal area and excludes the smaller barnacle from that area.
<b>Reason (R):</b>	Generally herbivores and plants appear to be more adversely affected by competition than carnivores.

In the light of the above statements, choose the correct answer from the options given below:

1.	Both (A) and (R) are True and (R) is the correct explanation of (A)
2.	Both (A) and (R) are True but (R) is not the correct explanation of (A)
3.	(A) is True but (R) is False.
4.	(A) is False but (R) is True.

**186** Given below are two statements:

<b>Statement I:</b>	Degeneration of corpus luteum in the absence of fertilization is the cause for disintegration of endometrium.
<b>Statement II:</b>	Cyclic menstruation indicates normal reproductive phase in human females and extends between menarche and menopause.

In the light of the above statements, choose the correct answer from the options given below:

- Both **Statement I** and **Statement II** are True.
- Both **Statement I** and **Statement II** are False.
- Statement I** is True but **Statement II** is False.
- Statement I** is False but **Statement II** is True.

**187** Given below are two statements: One is labelled as Assertion (A) and the other is labelled as Reason (R).

<b>Assertion (A):</b>	After death, the body muscles get stiff as a state of partial contraction of muscles.
<b>Reason (R):</b>	Attachment of myosin head to unexpected sites on action can take place partially.

In the light of the above statements, choose the correct answer from the options given below:

1.	Both (A) and (R) are True and (R) is the correct explanation of (A)
2.	Both (A) and (R) are True but (R) is not the correct explanation of (A)
3.	(A) is True but (R) is False.
4.	(A) is False but (R) is True.

**188** Match List-I with List-II

List-I (Cockroach)		List-II (Term Used)	
A.	Metamorphosis	I.	Ommatidia
B.	Brain	II.	Paurometabolous
C.	Vision	III.	Spiracles
D.	Respiration	IV.	Supraoesophageal ganglion

Choose the correct answer from the options given below:

- A-II, B-I, C-IV, D-III
- A-I, B-III, C-IV, D-II
- A-III, B-II, C-I, D-IV
- A-II, B-IV, C-I, D-III

**189** Given below are two statements: One is labelled as Assertion (A) and the other is labelled as Reason (R).

<b>Assertion (A):</b>	Some human organs like liver, kidney fail to function normally and transplantation is the only remedy to enable the patient to live a normal life.
<b>Reason (R):</b>	Tissue matching and blood group matching are essential before undertaking any transplant and patient has to take immunosuppressant thereafter.

In the light of the above statements, choose the correct answer from the options given below:

1.	Both (A) and (R) are True and (R) is the correct explanation of (A)
2.	Both (A) and (R) are True but (R) is not the correct explanation of (A)
3.	(A) is True but (R) is False.
4.	(A) is False but (R) is True.

**190** The manifestations of phenylketonuria are given below. Choose the incorrect answer from the given options:

- Mental retardation
- Skin rashes
- Excessive accumulation of phenylpyruvate in blood
- Furrowed tongue

**191** The epithelial tissue has the following features:

A.	Bear cilia on their free surface.
B.	Provides a lining for some parts of body.
C.	Compound epithelium is multilayered meant for limited role in secretion and absorption.
D.	Located in the tip of nose.
E.	Exocrine glands possess epithelial tissue.

Choose the most appropriate answer from the options given below:

1. B, D and E only
2. A, B and C only
3. B, C and E only
4. C, D and E only

**192** With regard to Hormones, identify the correct statements.

A.	Epinephrine is a peptide hormone.
B.	Progesterone is a peptide hormone.
C.	Hormones that interact with membrane bound receptors normally do not enter target cell, but generate second messengers.
D.	Hormones that interact with intracellular receptors mostly regulate gene expression.
E.	Insulin is a amino acid derivative hormone.

Choose the most appropriate answer from the options given below:

1. A and B only
2. C and E only
3. C and D only
4. B and C only

**193** Assuming Hardy Weinberg's Principle, in certain population the frequencies of three genotype are as follows:

Genotypes	AA	Aa	aa
Frequency	22%	62%	16%

What is likely frequency of 'A' and 'a' alleles?

1. 53% and 47%
2. 40% and 60%
3. 50% and 50%
4. 30% and 70%

**194** In human the process of respiration involves the following steps.

- A. Diffusion of gases across alveolar membrane
- B. Diffusion of gases between blood and tissues
- C. Transport of gases by blood
- D. Utilisation of  $O_2$  by the cells for catabolic reactions
- E. Breathing or pulmonary ventilation

Choose the correct sequence of steps from the options given below:

1. A →E→B→C→D
2. C →E→A→B→D
3. B →D→C→E→A
4. E →A→C→B→D

**195** In animal kingdom along with XX-YY mechanism, many other variants of chromosomal sex determination mechanism have been described such as XX-XO mechanism, ZZ-ZW mechanism ZZ-ZO mechanism and haplo-diploidy mechanism, which present respectively in:

1. Birds, Grasshopper, Wasp, Moth
2. Grasshopper, Birds, Moth, Wasp
3. Birds, Moth, Grasshopper, Wasp
4. Grasshopper, Moth, Birds, Wasp

**196** Given below are two statements:

<b>Statement I:</b>	The Golgi cisternae are concentrically arranged near the nucleus with distinct convex <i>cis</i> or the forming face and concave <i>trans</i> or the maturing face.
<b>Statement II:</b>	The <i>cis</i> and <i>trans</i> faces of the organelle are identical and interconnected.

In the light of the above statements, choose the correct answer from the options given below:

1. Both **Statement I** and **Statement II** are True.
2. Both **Statement I** and **Statement II** are False.
3. **Statement I** is True but **Statement II** is False.
4. **Statement I** is False but **Statement II** is True.

**197** Given below are two statements: One is labelled as Assertion (A) and the other is labelled as Reason (R).

<b>Assertion (A):</b>	Juxta Glomerular Apparatus (JGA) plays an important role in regulation of glomerular filtration rate (GFR).
<b>Reason (R):</b>	A fall in GFR can activate the J.G. cells to release renin which can stimulate the glomerular blood flow and there by bringing the GFR to normal level.

In the light of the above statements, choose the correct answer from the options given below:

1.	Both (A) and (R) are True and (R) is the correct explanation of (A).
2.	Both (A) and (R) are True but (R) is not the correct explanation of (A).
3.	(A) is True but (R) is False.
4.	(A) is False but (R) is True.

**198** Given below are two statements: One is labelled as Assertion (A) and the other is labelled as Reason (R).

<b>Assertion (A):</b>	In hemichordates the body cavity is lined by mesoderm.
<b>Reason (R):</b>	In aschelminthes the body cavity is not lined by mesoderm

In the light of the above statements, choose the correct answer from the options given below:

1.	Both (A) and (R) are True and (R) is the correct explanation of (A).
2.	Both (A) and (R) are True but (R) is not the correct explanation of (A).
3.	(A) is True but (R) is False.
4.	(A) is False but (R) is True.

**199** Given below are two statements: One is labelled as Assertion (A) and the other is labelled as Reason (R).

<b>Assertion (A):</b>	There is always a sharp decline in dissolved oxygen downstream from the point of sewage discharge, which causes mortality of fish and other aquatic creatures
<b>Reason (R):</b>	Micro-organisms involved in bio-degradation of organic matter in the receiving water body consumes a lot of oxygen

In the light of the above statements, choose the correct answer from the options given below:

1.	Both (A) and (R) are True and (R) is the correct explanation of (A).
2.	Both (A) and (R) are True but (R) is not the correct explanation of (A).
3.	(A) is True but (R) is False.
4.	(A) is False but (R) is True.

**200** Match List-I with List-II:

List-I (Events)		List-II (Prophase-I)
A. Chromosomes start pairing together to form synaptonemal complex	I.	Pachytene
B. Chromosomes visible under light microscope and compaction continues	II.	Zygotene
C. Four chromatids of bivalent chromosomes become distinct and recombinant nodules appear	III.	Diplotene
D. Dissolution of synaptonemal complex	IV.	Leptotene

Choose the correct answer from the options given below:

1. A-II, B-I, C-IV, D-III
2. A-I, B-IV, C-III, D-III
3. A-III, B-II, C-IV, D-I
4. A-II, B-IV, C-I, D-III